

Example

The circuit shown in (a) has been divided into two parts. In (b), the right-hand part has been replaced with an equivalent circuit. The left-hand part of the circuit has not been changed. Determine the value of the current i_2 .

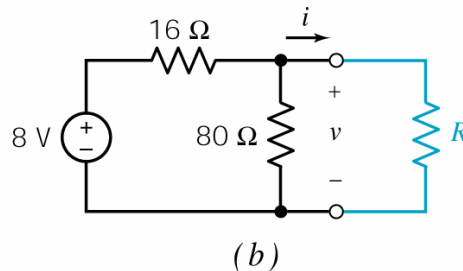
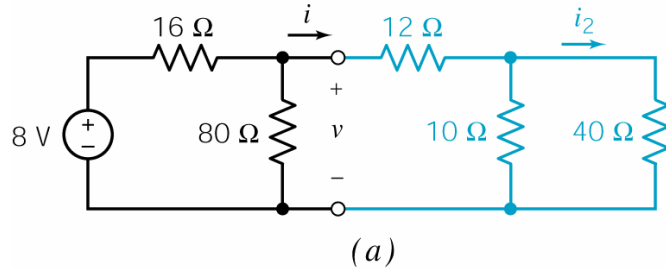

Solution:

1. Determine the value of the resistance R in (b) that makes the circuit in (b) equivalent to the circuit in (a).

$$R = 12 + \frac{10 \cdot 40}{10 + 40} = 20 \Omega$$

2. Find the current i and the voltage v shown in (b).

R is in parallel with the 80Ω resistor. The equivalent resistance, $R \parallel 80$, is in series with the 16Ω resistor. Using voltage division gives

$$v = \frac{R \parallel 80}{16 + (R \parallel 80)} = \frac{\frac{20 \cdot 80}{20 + 80}}{16 + \frac{20 \cdot 80}{20 + 80}} \cdot 8 = \frac{16}{16 + 16} \cdot 8 = 4 \text{ V}$$

Using Ohm's law

$$i = \frac{4}{20} = 0.2 \text{ A}$$

Because of the equivalence, the current i and the voltage v shown in (a) are equal to the current i and the voltage v shown in (b).

3. Find the current i_2 shown from i using current division.

$$i_2 = \frac{10}{10+40} \cdot i = \frac{10}{50} \cdot 0.2 = 0.04 \text{ A} = 40 \text{ mA}$$

How can we check our calculations? Let's apply KVL to the loop shown below

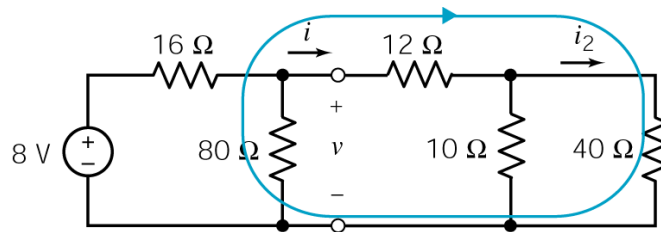

We get

$$12i + 40i_2 - v = 0$$

Notice that this equation involves all three of the values that we calculated. If our values satisfy this equation, it's likely that they are correct. Substituting the calculated values gives

$$12(0.2) + 40(0.04) - 4 = 2.4 + 1.6 - 4 = 0$$

The calculated values do satisfy the KVL equation and it's likely that they are correct. Suppose we aren't satisfied and want to check further. Apply KCL at the top node of the 80-Ω resistor to get

$$\frac{8-v}{16} = \frac{v}{80} + i$$

Substituting the calculated values into this equation gives

$$\frac{8-4}{16} = \frac{4}{80} + 0.2 \Rightarrow 0.25 = 0.05 + 0.2$$

The calculated values do satisfy this KCL equation. We can be confident that they are correct.

Example:

The circuit shown in (a) has been divided into three parts. In (b), the rightmost part has been replaced with an equivalent circuit. The rest of the circuit has not been changed. The circuit is simplified further in (c). Now the middle and rightmost parts have been replaced by a single equivalent resistance. The leftmost part of the circuit is still unchanged.

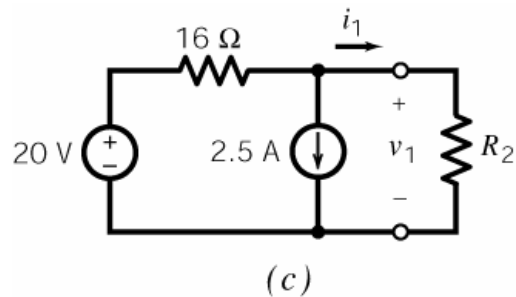
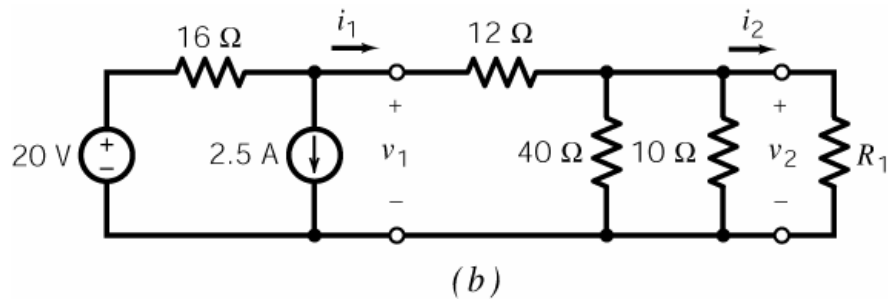
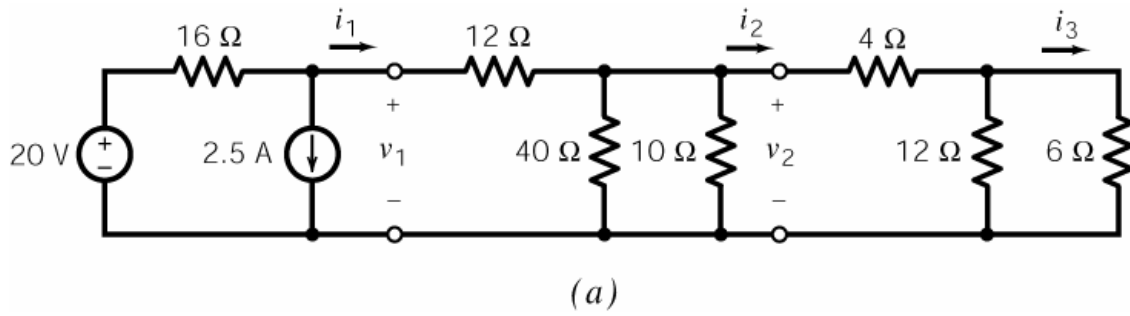

Solution

1. Determine the value of the resistance R_1 in (b) that makes the circuit in (b) equivalent to the circuit in (a).

$$R_1 = 4 + \frac{12 \cdot 6}{12 + 6} = 8 \Omega \quad (1)$$

2. Determine the value of the resistance R_2 in (c) that makes the circuit in (c) equivalent to the circuit in (b).

First

$$40 \parallel 10 \parallel R_1 = 40 \parallel 10 \parallel 8 = \frac{1}{\frac{1}{40} + \frac{1}{10} + \frac{1}{8}} = \frac{1}{0.025 + 0.1 + 0.125} = \frac{1}{0.25} = 4 \Omega$$

Then

$$R_2 = 12 + (40 \parallel 10 \parallel R_1) = 12 + (40 \parallel 10 \parallel 8) = 16 \Omega \quad (2)$$

3. Find the current i_1 and the voltage v_1 shown in (c).

Using Ohm's and Kirchhoff's laws

$$20 = 16 \left(2.5 + \frac{v_1}{R_2} \right) + v_1 = 40 + \left(1 + \frac{16}{R_2} \right) v_1 = 40 + 2v_1 \Rightarrow v_1 = \frac{-20}{2} = -10 \text{ V} \quad (3)$$

Then using Ohm's law

$$i_1 = \frac{v_1}{R_2} = \frac{-10}{16} = -0.625 \text{ A} \quad (4)$$

Because circuits (b) and (c) are equivalent, the current i_1 and the voltage v_1 shown in (b) are equal to the current i_1 and the voltage v_1 shown in (c).

4. Find the current i_2 and the voltage v_2 shown in (b).

Using voltage division

$$v_2 = \frac{(40 \parallel 10 \parallel R_1)v_1}{12 + (40 \parallel 10 \parallel R_1)} = \frac{(40 \parallel 10 \parallel 8)(-10)}{12 + (40 \parallel 10 \parallel 8)} = \frac{4(-10)}{12 + 4} = -2.5 \text{ V} \quad (5)$$

Then using Ohm's law

$$i_2 = \frac{v_2}{R_1} = \frac{-2.5}{8} = -0.3125 \text{ A} \quad (6)$$

Because circuits (a) and (b) are equivalent, the current i_2 and the voltage v_2 shown in (a) are equal to the current i_2 and the voltage v_2 shown in (b).

5. Find the current i_3 shown in (a).

Using current division

$$i_3 = \frac{12i_2}{12 + 6} = \frac{12(-0.3125)}{18} = -0.2083 \text{ A} \quad (7)$$

How can we check our calculations? Let's see if we get the same values using MATLAB. First, collect equations 1-7 in a MATLAB "m-file":

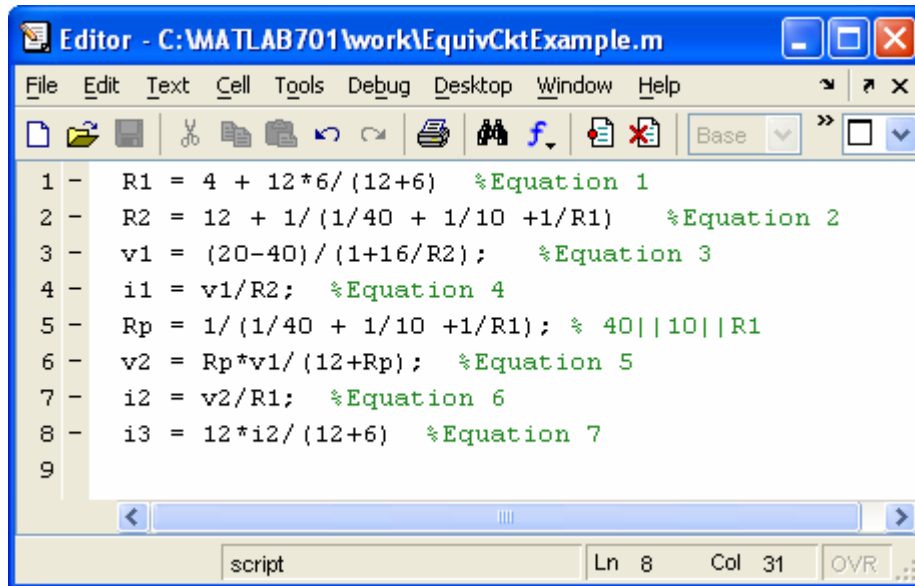

```
Editor - C:\MATLAB701\work\EquivCktExample.m
File Edit Text Cell Tools Debug Desktop Window Help
1 - R1 = 4 + 12*6/(12+6) %Equation 1
2 - R2 = 12 + 1/(1/40 + 1/10 +1/R1) %Equation 2
3 - v1 = (20-40)/(1+16/R2); %Equation 3
4 - i1 = v1/R2; %Equation 4
5 - Rp = 1/(1/40 + 1/10 +1/R1); % 40||10||R1
6 - v2 = Rp*v1/(12+Rp); %Equation 5
7 - i2 = v2/R1; %Equation 6
8 - i3 = 12*i2/(12+6) %Equation 7
9
script Ln 8 Col 31 OVR
```

Next, running that m-file gives

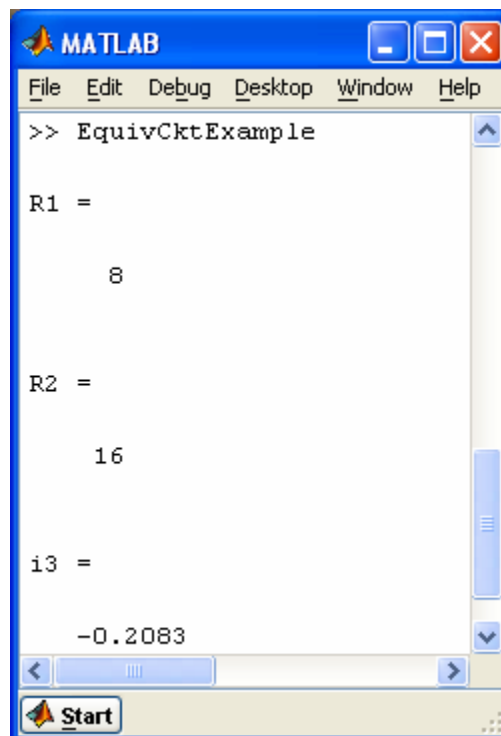

```
MATLAB
File Edit Debug Desktop Window Help
>> EquivCktExample

R1 =

    8

R2 =

   16

i3 =

  -0.2083

Start
```

As expected, these values agree with our calculated values.

Exercises:

Problems 3.7-1 and 3.7-2 in *Introduction to Electric Circuits* are similar to these examples.