

## Sample ES 250 Second Midterm Exam

1.

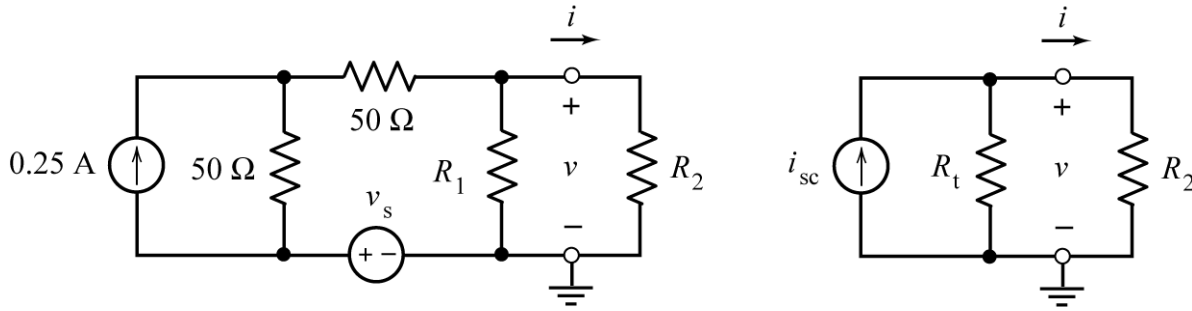

The part of the first circuit to the left of the terminals can be reduced to its Norton equivalent circuit using source transformations and equivalent resistance. The resulting Norton equivalent circuit will be characterized by the parameters:

$$i_{sc} = 0.5 \text{ A} \quad \text{and} \quad R_t = 20 \text{ } \Omega$$

Determine the values of  $v_s$  and  $R_1$ :  $v_s = \underline{37.5} \text{ V}$  and  $R_1 = \underline{25} \text{ } \Omega$

Given that  $0 \leq R_2 \leq \infty$ , determine the maximum values of the voltage,  $v$ , and of the power,  $p = vi$ :

$$\max v = \underline{10} \text{ V} \quad \text{and} \quad \max p = \underline{1.25} \text{ W}$$

2. Given that  $0 \leq R \leq \infty$  in this circuit, consider these two observations:

When  $R = 2 \text{ } \Omega$  then  $v_R = 4 \text{ V}$  and  $i_R = 2 \text{ A}$ .

When  $R = 6 \text{ } \Omega$  then  $v_R = 6 \text{ V}$  and  $i_R = 1 \text{ A}$ .

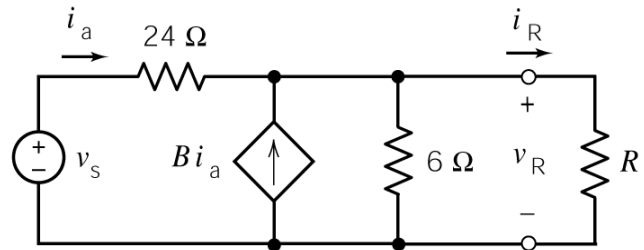

Fill in the blanks in the following statements:

- a. The maximum value of  $i_R$  is  $\underline{4} \text{ A}$ .
- b. The maximum value of  $v_R$  is  $\underline{8} \text{ V}$ .
- c. The maximum value of  $p_R = i_R v_R$  occurs when  $R = \underline{2} \text{ } \Omega$ .
- d. The maximum value of  $p_R = i_R v_R$  is  $\underline{8} \text{ W}$ .
- e. When  $R = 5 \text{ } \Omega$  then  $v_R = \underline{5.714} \text{ V}$ .
- f. When  $R = \underline{8} \text{ } \Omega$  then  $v_R = 6.4 \text{ V}$ .
- g. When  $R = \underline{14} \text{ } \Omega$  then  $i_R = 500 \text{ mA}$ .

3. Determine the values of the node voltages  $v_a$  and  $v_o$ :

$v_a = \underline{\quad -4.5 \quad}$  V and  $v_o = \underline{\quad -9 \quad}$  V.

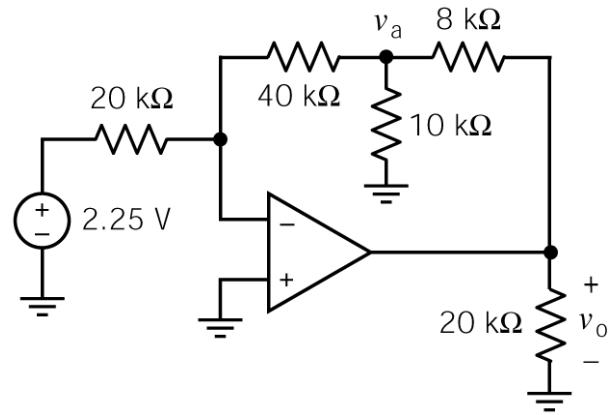

4.

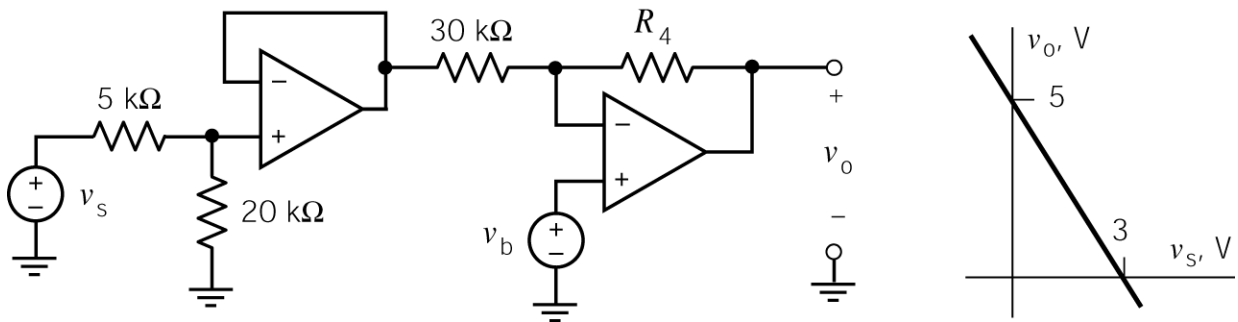

The input to this circuit is the voltage,  $v_s$ . The output is the voltage  $v_o$ . The voltage  $v_b$  is used to adjust the relationship between the input and output. Determine values of  $R_4$  and  $v_b$  that cause the circuit input and output have the relationship specified by the graph

$v_b = \underline{\quad 1.62 \quad}$  V and  $R_4 = \underline{\quad 62.5 \quad}$  kΩ.

5. One of these three elements is a resistor, one is a capacitor and one is an inductor:

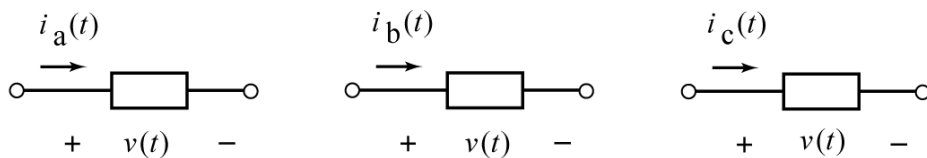

Given  $v(t) = 24 \cos(5t)$  V,

And  $i_a(t) = 3 \cos(5t)$  A,  $i_b(t) = 12 \sin(5t)$  A and  $i_c(t) = -1.8 \sin(5t)$  A

Determine the resistance of the resistor, the capacitance of the capacitor and the inductance of the inductor. (We require positive values of resistor, capacitance and inductance.)

resistance =  $\underline{\quad 8 \quad}$  Ω, capacitance =  $\underline{\quad 0.015 \quad}$  F and inductance =  $\underline{\quad 0.4 \quad}$  H

6. Consider this inductor. The current and voltage are given by

$$i(t) = \begin{cases} 5t - 4.6 & 0 \leq t \leq 0.2 \\ at + b & 0.2 \leq t \leq 0.5 \\ c & t \geq 0.5 \end{cases} \quad \text{and} \quad v(t) = \begin{cases} 12.5 & 0 < t < 0.2 \\ 25 & 0.2 < t < 0.5 \\ 0 & t > 0.5 \end{cases}$$

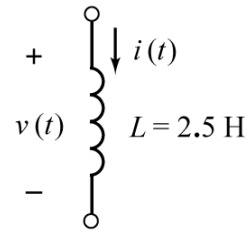

where a, b and c are real constants. (The current is given in Amps, the voltage in Volts and the time in seconds.) Determine the values of the constants:

$$a = \underline{10} \text{ A/s}, \quad b = \underline{-5.6} \text{ A} \quad \text{and} \quad c = \underline{-0.6} \text{ A}$$

7. This circuit is at steady state when the switch opens at time  $t = 0$ .

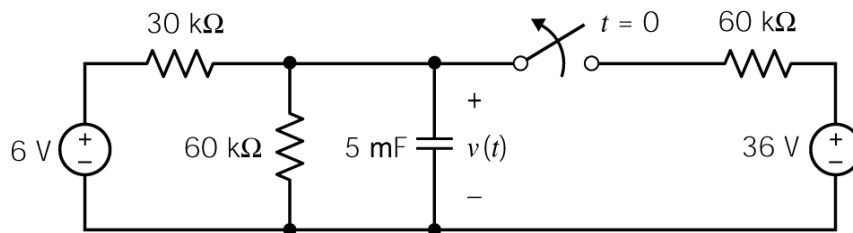

The capacitor voltage is  $v(t) = A - B e^{-at}$  for  $t \geq 0$ . Determine the values of the constants A, B, and a:

$$A = \underline{4} \text{ V}, \quad B = \underline{8} \text{ V} \quad \text{and} \quad a = \underline{0.01} \text{ s}^{-1}$$

8. This circuit is at steady state before the switch closes at time  $t = 0$ .

After the switch closes, the inductor current is given by

$$i(t) = 0.6 - 0.2 e^{-5t} \text{ A} \quad \text{for } t \geq 0$$

Determine the values of  $R_1$ ,  $R_2$  and  $L$ :

$$R_1 = \underline{20} \text{ } \Omega, \quad R_2 = \underline{10} \text{ } \Omega \quad \text{and} \quad L = \underline{4} \text{ H}$$

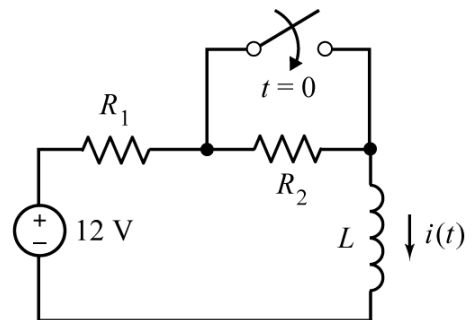

9.

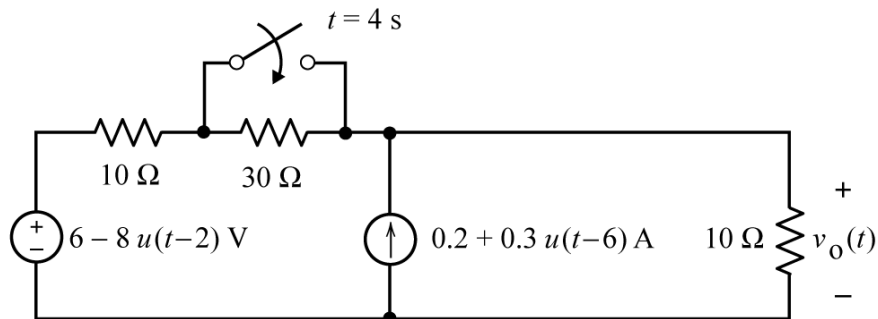

Determine  $v_o(1)$ ,  $v_o(3)$ ,  $v_o(5)$ , and  $v_o(7)$ ; the values of the voltage  $v_o(t)$  at times  $t = 1, 3, 5$  and  $7$  seconds.

$$v_o(1) = \underline{2.8} \text{ V}, \quad v_o(3) = \underline{1.2} \text{ V}, \quad v_o(5) = \underline{0} \text{ V}, \quad \text{and} \quad v_o(7) = \underline{1.5} \text{ V}$$