

ES 250 1st Midterm Exam - Fall 2013

Name _____

Student # _____

1. Here are 4 separate circuits. Determine the values of i_1 , i_2 , i_3 and i_4 .

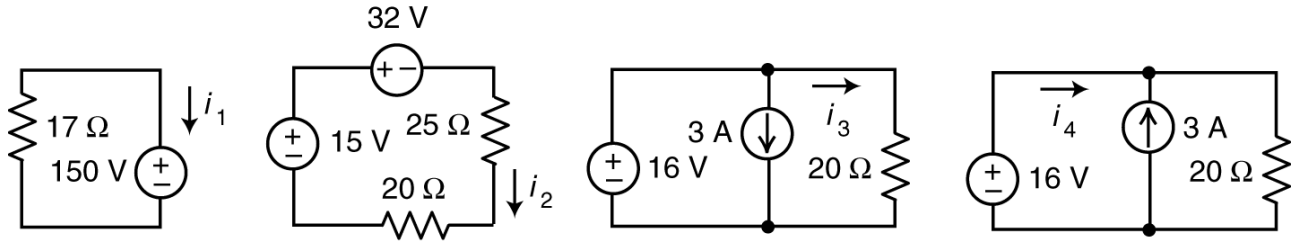

$i_1 = \underline{-8.82}$ A, $i_2 = \underline{-0.3778}$ A, $i_3 = \underline{0.80}$ A and $i_4 = \underline{-2.2}$ A.

2. Determine the values of the gains of the dependent sources.

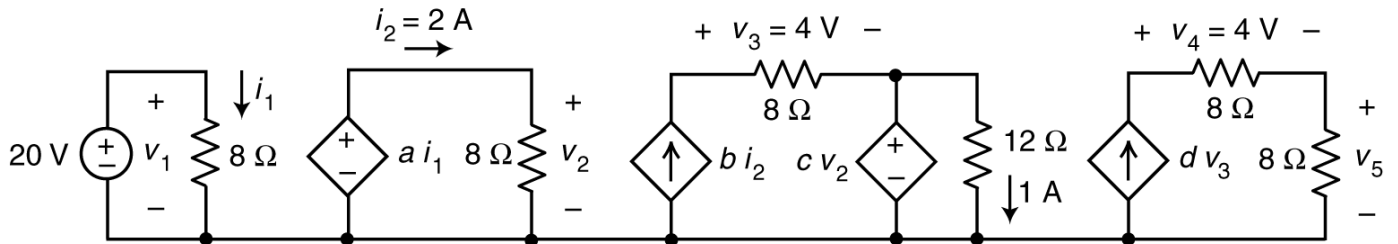

$a = \underline{6.4}$ V/A, $b = \underline{0.25}$ A/A, $c = \underline{0.75}$ V/V and $d = \underline{0.125}$ A/V.

3. Here are 4 separate circuits. Determine the values of v_1 , i_2 , v_3 and i_4 .

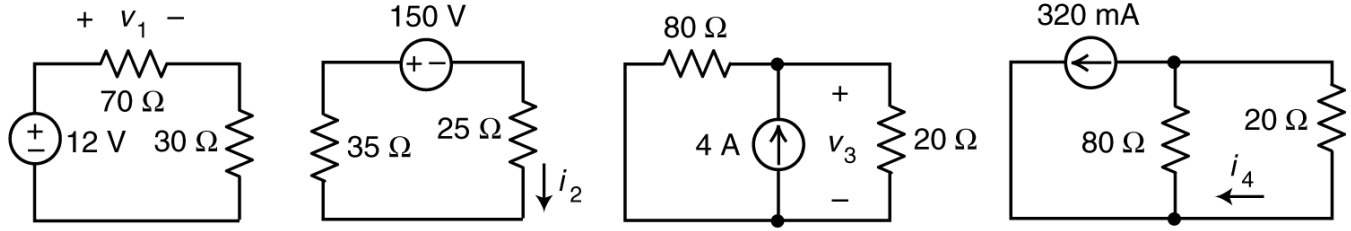

$v_1 = \underline{8.4} \text{ V}$, $i_2 = \underline{-2.5} \text{ A}$, $v_3 = \underline{64} \text{ V}$ and $i_4 = \underline{-256} \text{ mA}$.

4.

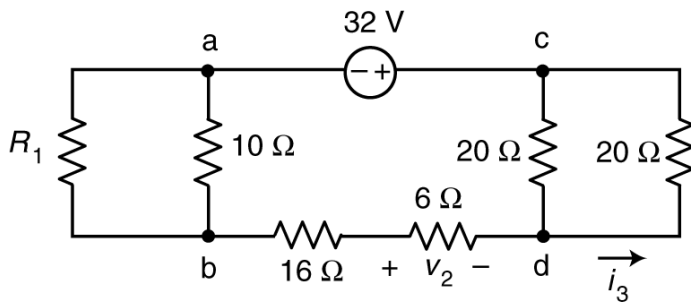

original circuit

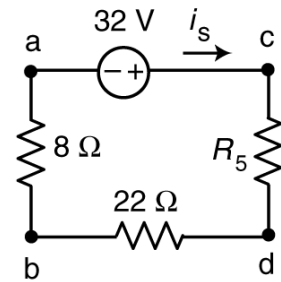

equivalent circuit

The equivalent circuit on the right is obtained from the original circuit on the left by replacing parallel combinations of resistors by equivalent resistors. The value of the current in the equivalent circuit is

$i_s = 0.8 \text{ A}$. Determine the values of the following:

$R_1 = \underline{40} \text{ } \Omega$, $R_5 = \underline{10} \text{ } \Omega$, $v_2 = \underline{-4.8} \text{ V}$, and $i_3 = \underline{-0.4} \text{ A}$.

5.

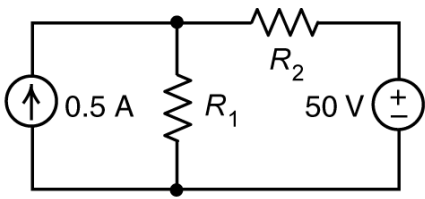

The voltage source supplies 15 W of power and the current source supplies 16 W of power. Determine the values of the resistances.

$R_1 = \underline{40} \ \Omega$ and $R_2 = \underline{60} \ \Omega$

6. Consider this voltage divider circuit. The vertical resistor represents a temperature sensor. Suppose the resistance R , in Ω , is related to the temperature T , in $^\circ\text{C}$, by the equation

$$R = 50 + 1.5T$$

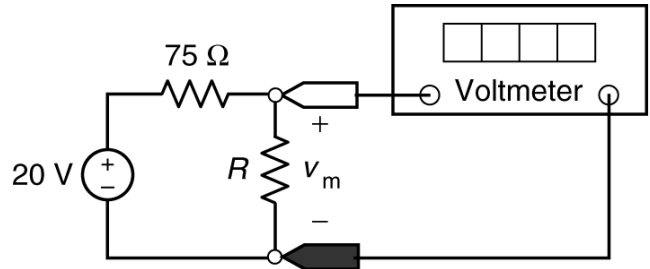

(a) Suppose the temperature is $T = 40 \ ^\circ\text{C}$. The voltage measured by the meter will be $v_m = \underline{11.89} \ \text{V}$.

(b) Suppose instead that $v_m = 14 \ \text{V}$. The corresponding temperature is $T = \underline{83.33} \ ^\circ\text{C}$.

7. Here are two ways to measure equivalent resistance. Determine the value of the resistance R_{eq} measured by the Ohmmeter and of the voltage V_m measured by the voltmeter.

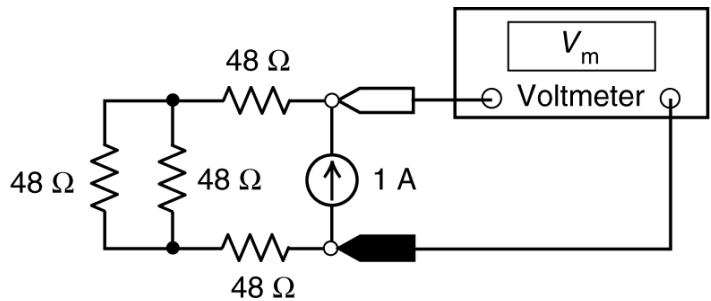
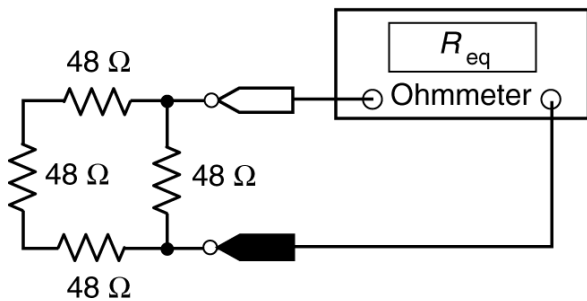

$R_{eq} = \underline{36} \ \Omega$ and $V_m = \underline{120} \ \text{V}$

8.

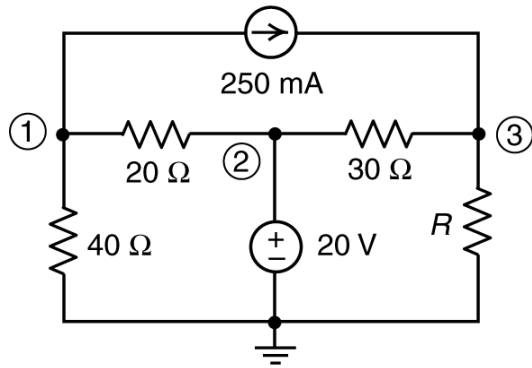

Encircled numbers are node numbers. The corresponding node voltages are:

$$v_1 = 10 \text{ V}, v_2 = 20 \text{ V and } v_3 = 16.5 \text{ V}$$

The resistance of the resistor at the right of the circuit is

$$R = \underline{\quad 45 \quad} \Omega.$$

The power **received** by the 40-Ω resistor is $\underline{\quad 2.5 \quad}$ W

The power supplied by the independent voltage source is $\underline{\quad 12.33 \quad}$ W.

The power supplied by the independent current source is $\underline{\quad 1.625 \quad}$ W.

9.

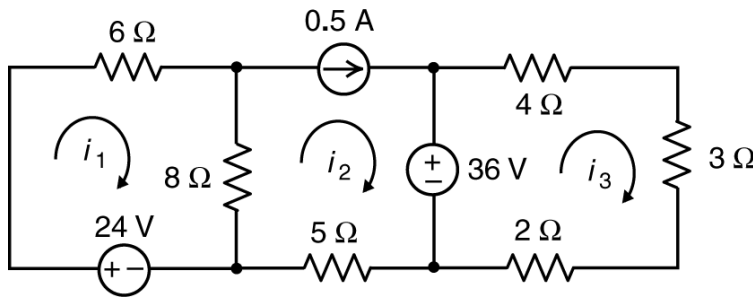

The mesh currents in this circuit are:

$$i_1 = 2 \text{ A}, i_2 = 0.5 \text{ A}$$

and $i_3 = 4 \text{ A}$

Determine the following powers:

The 36-V voltage source supplies $\underline{\quad 126 \quad}$ W.

The 24-V voltage source supplies $\underline{\quad 48 \quad}$ W.

The 8-Ω resistor receives $\underline{\quad 18 \quad}$ W.

The 5-Ω resistor receives $\underline{\quad 1.25 \quad}$ W.