

Electric Circuits:

The circuits considered in this course can be categorized as **lumped, linear, time-invariant** circuits.

- **Lumped** circuits can be represented by ordinary differential equations. In contrast, **distributed** circuits require partial differential equations. Lumped circuits are easier to analyze than are distributed circuits.
- The principle of **superposition** applies to **linear** circuits but not to **nonlinear** circuits. Consequently, linear circuits are easier to analyze than are nonlinear circuits. (We'll have more to say about superposition later.)
- The operation **time-varying** circuits depends on the time at which they are used. **Time-invariant** circuit work the same way regardless of when they are used. Time-invariant circuits are easier to analyze than are time-varying circuits.

In general, we analyze an electric circuit by writing and solving a differential equation.

Example:

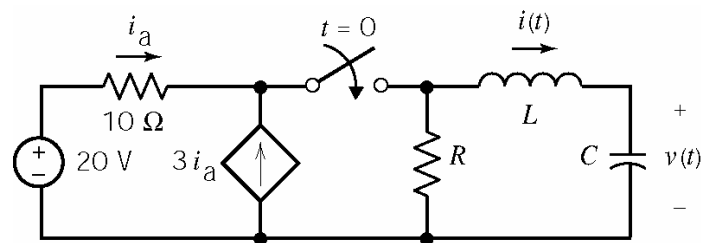

After the switch closes, this circuit is represented by the differential equation

$$\frac{d^2}{dt^2} i(t) + \left(\frac{10R}{(3R+10)L} \right) \frac{d}{dt} i(t) + \left(\frac{1}{CL} \right) i(t) = \frac{20}{CL} \quad \text{for } t > 0$$

When

- 1) $R = 10 \Omega$, $L = 0.4 \text{ H}$ and $C = 0.25 \text{ mF}$
- 2) The circuit is at steady state before the switch closes.

The capacitor voltage, $v(t)$, can be shown to be

$$v(t) = 16 + 16.525 e^{-2.5t} \cos(9.682t + 165.5^\circ) \text{ V for } t \geq 0$$

Circuits containing capacitors or inductors are called **dynamic** circuits. In contrast, circuits that contain no capacitors or inductors are called **static** circuits. Dynamic electric circuits are represented by differential equations but static electric circuit can be represented using algebraic equations. Static circuits are easier to analyze than are dynamic circuits.

DC circuits are static electric circuits in which all of the independent sources are constant. That is, the voltages of the independent voltage sources have constant values and the currents of the independent current sources have constant values. All of the element voltages and currents of a dc circuit have constant values.

Example:

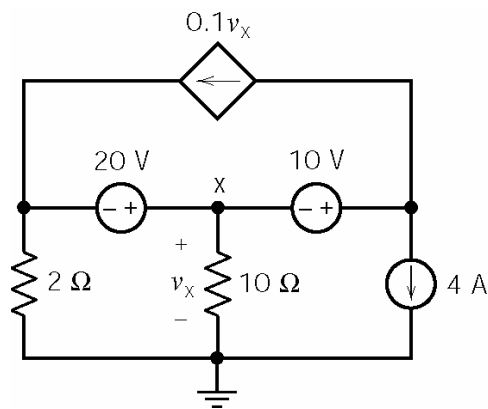

This dc circuit is represented by the algebraic equation

$$\frac{v_x - 20}{2} + \frac{v_x}{10} + 4 = 0$$

Solving this algebraic equation gives

$$v_x = 10 \text{ V}$$

AC circuits are dynamic electric circuits in which

- The circuit is at steady state. (More on this later.)
- All of the independent sources are sinusoidal and have the same frequency. That is, the voltages of the independent voltage sources are sinusoidal functions of time and the currents of the independent current sources are sinusoidal functions of time.

All of the element voltages and currents of a ac circuit are sinusoidal functions of time.

Example:

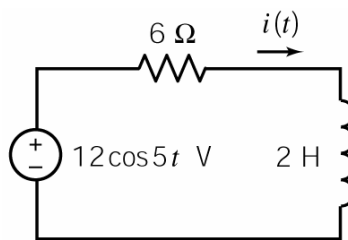

This ac circuit is represented by the differential equation

$$6i(t) + 2 \frac{d}{dt} i(t) = 12 \cos 5t$$

Solving this differential equation, we find that the steady-state current is

$$i(t) = 1.03 \cos(5t - 59^\circ) \text{ A}$$

Observation:

DC circuits are easier to analyze than are dynamic circuits, including ac circuits.

Our plan:

First, we will develop methods for analyzing dc circuits (e.g. writing mesh and node equations or finding Thevenin equivalent circuits). Later, we will use these methods to analyze dynamic circuits, including ac circuits.