

Prediction of Electromagnetic Forces and Vibrations in SRMs Operating at Steady State and Transient Speeds

Zhangjun Tang
Stryker Instruments
Kalamazoo, MI 49001
Phone: 269-323-7700 Ext.3603
Fax: 269-323-3094
ztang@inst.strykercorp.com

Pragasen Pillay
ECE Department
Clarkson University
Potsdam, NY 13699
Phone: 315-268-6509
Fax: 315-268-7600
pillayp@clarkson.edu

Yicheng Chen
ECE Department
Clarkson University
Potsdam, NY 13699
Phone: 315-268-6409
Fax: 315-268-7600
yicheng@clarkson.edu

Avoki M. Omekanda
Delphi Research Labs
51786 Shelby Parkway
Shelby Township, MI 48306
Phone: (586) 323-6161
Fax: (596) 323-9898
avoki.omekanda@delphi.com

Abstract Although some research has been conducted on vibrations in switched reluctance motors, the response during transients, which may occur during sudden load changes or braking, has not received much investigation. In this paper, a simulation model to predict the transient vibration of SRMs is developed. The vibration prediction model is built based on the detailed normal force vs. phase current and rotor position lookup table using finite element calculations. The model is then verified by a running motor test, which shows acceptable accuracy. The results reveal that there are abundant harmonics of transient force during transients, and thus resonance may be excited. This model allows the possibility of improved design of SRMs from a vibration and acoustic noise, point of view.

I. INTRODUCTION

The subject of vibrations in switched reluctance motors has attracted recent attention, including vibration tests [1] [2], modal analysis [3], and resonant frequency calculations [4]. However, the transient vibration during start-up, braking, and sudden load change remains unknown. In some circumstances, the transient vibration is more important than the steady state value, because the SRM is running in the transient state most of the time, for example with the application of the SRM as a braking motor in automobiles.

It is now well known that the normal force between SRM stator poles and rotor poles causes an attraction and thus an ovalization of the stator, which is the main cause of SRM vibration and acoustic noise [1]. The normal force in the SRM is very difficult to measure from experiment, and cannot be easily and accurately modeled analytically, because of the double saliency of the stator and rotor poles, as well as the highly saturated nature of the flux density.

The normal forces, which excites vibrations in SRMs, depends largely on the transient current. The simulation of the SRM phase current are in several papers [5] [6] [7]. PSpice and Matlab/SIMULINK have been used, with acceptable results. Both linear and non-linear models have

been used in those papers. The phase current waveforms after reaching steady state as well as during start-up were shown. However, the operation during sudden load changes or braking, have not been investigated.

In this paper, the simulation of transient vibrations during different operating conditions, such as start-up, sudden load change, and braking, is developed. The vibration prediction model is based on the detailed normal force vs. phase current and rotor position lookup table using finite element calculations. To verify the simulation results, the running motor test is driven by a classic converter controlled by dSPACE, which has the functions of DSP and AD/DA, and can be run in a Matlab/Simulink environment. An 8/6, 4kW SRM is used for experimental validation of the simulation results. Both phase current and stator vibration are measured, with acceptable accuracy.

II. NUMERICAL CALCULATION OF NORMAL FORCE AND LOOKUP TABLE CONSTRUCTION

Because of the structural complexity of SRMs and highly saturated nature of the flux density, it is very difficult to accurately model the normal force analytically. Thus, a 2-D non-linear finite element model in ANSYS is used, for the electromagnetic force analysis. A 4kW, 8/6 pole SRM with four phases is used in this research. Fig.1 shows the meshing of the elements for the model. Fig.2 has the flux linkage plot of the motor.

Static force calculations are carried out for 31 angles from the aligned to unaligned position and 25 different currents from 1A to 25A. Fig.3 shows the force plot of the SRM. It is clear that the normal force dominates the tangential force, and the force concentrates on the stator pole – rotor pole area. Fig.4 is the plot of the normal force vs. phase current & rotor position.

This normal force vs. phase current & rotor position lookup table can now be used to obtain the actual normal force acting on the stator for an arbitrary phase current waveform, as long as the current waveform is known. It will be used to determine the transient forces and force

harmonics, and hence to calculate the vibration resulting from the normal forces.

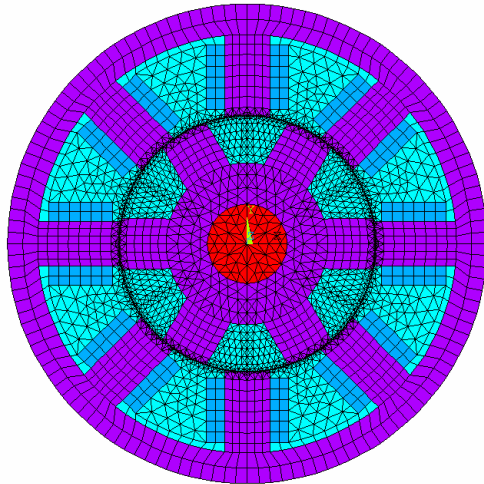

Fig.1 Finite Element Meshing for Electromagnetic Analysis

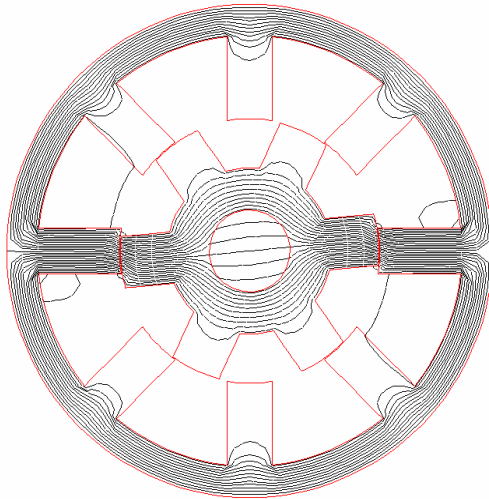

Fig.2 Flux Linkage Plot

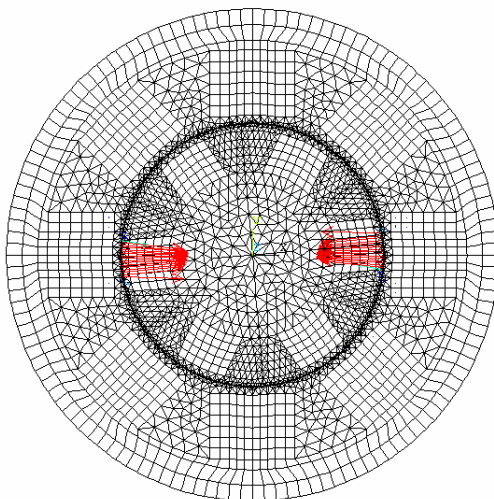

Fig.3 Force Plot

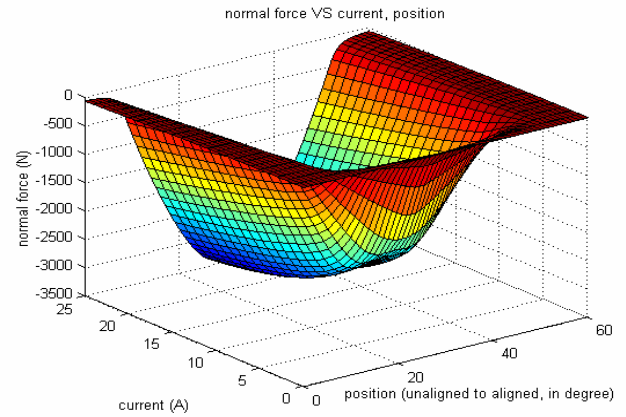

Fig.4 Normal Force vs. Phase Current & Rotor Position

III. MODELLING AND SIMULATION OF TRANSIENT CURRENTS

A. SRM Dynamics

The operation and modeling of SRMs is entirely different from conventional motors. The complication in modeling is due to the highly nonlinear nature of the motor. There have been many attempts to model SRMs [5-7], which basically differ in variables chosen for solution, therefore requiring different data sets. It is convenient to choose the governing equations as following.

Electromagnetic equation:

$$\frac{d\Psi}{dt} = v - Ri \quad (1)$$

where ψ is the flux linkage in the phase winding, v is the terminal voltage, i and R are phase current and phase winding resistance respectively.

Mechanical equation:

$$T = T_l + k_\omega \omega + J \frac{d\omega}{dt} \quad (2)$$

$$\omega = \frac{d\theta}{dt} \quad (3)$$

where T is the electromagnetic torque, T_l is the load torque, k_ω is the friction damping coefficient, J is the moment of inertia of the rotor, ω is the rotor speed.

It is obvious that the above equations have no analytical solution as the flux linkage is a nonlinear function of current and rotor angle, hence numerical analysis is necessary.

B. Simulation of currents

Instead of using a linear model of the SRM, two look-up tables are used in this simulation. One is flux linkage vs. rotor position and phase current; the other is phase current and rotor position vs. torque. The simulation model is

shown in Fig.5, with (a) being the entire model, and (b) being the sub-system for each phase, which includes two look-up tables and is used to calculate the electromagnetic torque.

The data for the first look-up table can be obtained from FEM calculations (if the motor is in the design stage), or from experimental test results (if the prototype exists). In this paper the data is measured from experimental tests. Fig.6 shows the flux linkage vs. phase current and rotor position.

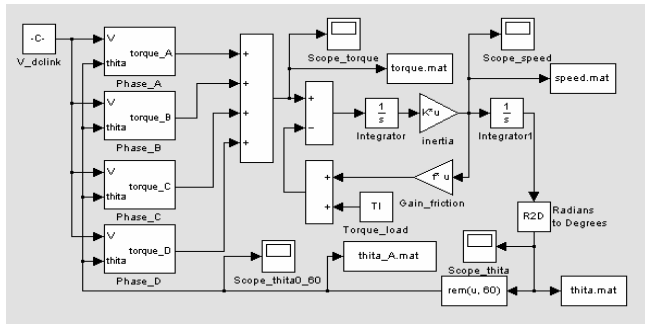

(a) Entire Model

(b) Simulation Block for One Phase

Fig.5 Simulation Model for SRM — Look-up Table Method

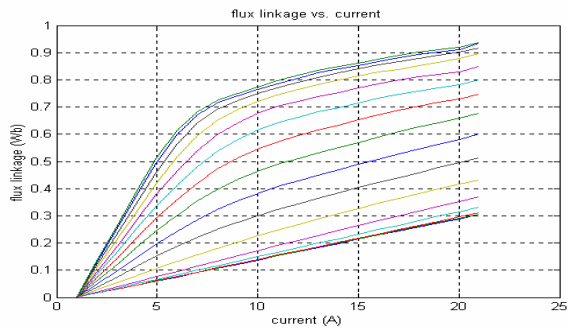

(a) Flux-linkage vs. Current at Different Rotor Positions

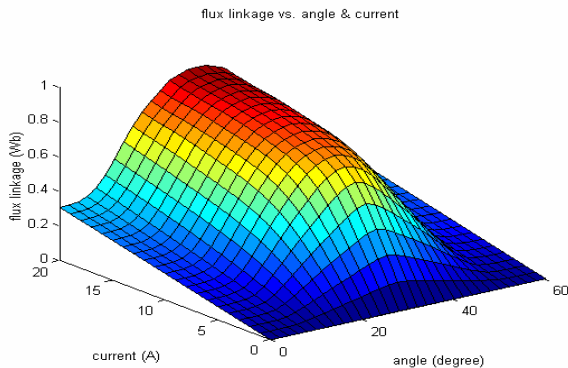

(b) 3-D View of Flux-linkage vs. Current & Rotor Position
Fig.6 Flux Linkage vs. Phase Current and Rotor Position

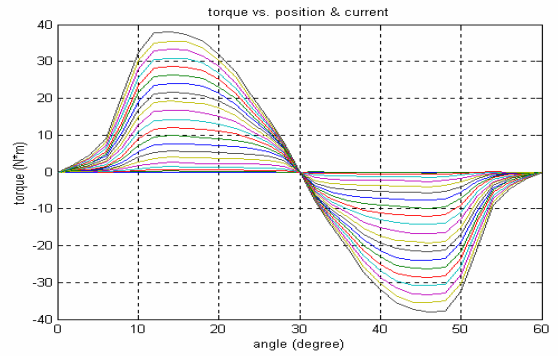

Fig.7 Torque vs. Rotor Position and Phase Current

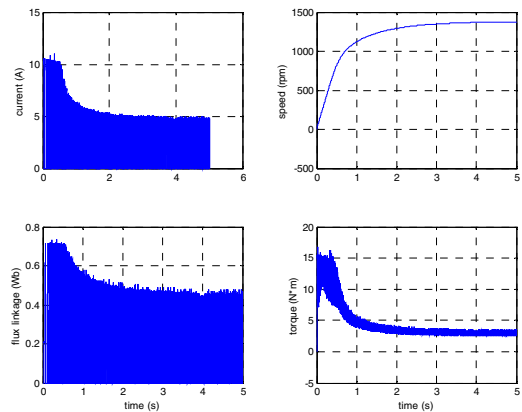

Fig.8 Simulated Transient Phase Current, Rotor Speed, Flux Linkage and Torque (Accelerating)

The torque vs. rotor position and phase current look-up table can also be obtained from FEM calculations or experimental tests. Again the data used in this paper is measured from experimental tests, which is shown in Fig.7.

Fig.8 shows the simulated transient results of phase current, flux linkage, speed and total torque. It is for operation at speed of 1320 rpm, with turn-on angle at 7° and turn-off angle at 22.5° .

C. Braking and Sudden Change of Torque Operation

In industrial applications, SRMs do not always run at constant speed. Thus, it is necessary to analyze SRM operations under the condition of sudden change of torque/speed and even the operating status when changing from motoring to generating/braking.

The simulation model shown in Fig.5 is good for simulating the SRM's start-up from zero to full speed, then remaining at that constant speed. By adding two

“switches”, one called a “Direction switch”, the other called an “Extra load switch”, the model will be able to simulate the operation with a change of load, and braking. This new model is shown in Fig.9.

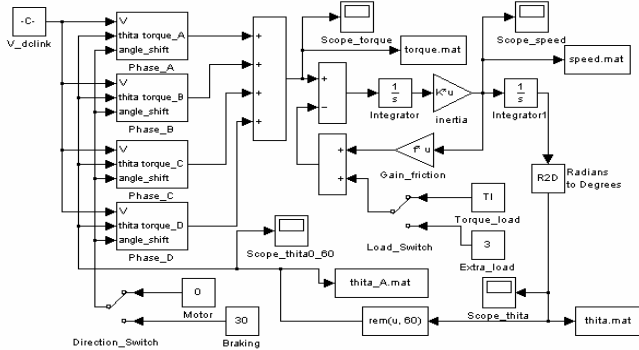

Fig.9 Simulation Model for Sudden Load Change and Braking Operations

The SRM can be easily operated with regenerative braking, when the turn-on angle θ_{on} is increased to make most of the phase current appear in the $\frac{\partial L}{\partial \theta} < 0$ area. It is still one of the APC (Angular Position Control) modes. During braking, the direction of electromagnetic torque is opposite to the rotor rotation. The mechanical energy in the rotor is transformed to electrical energy, which will be fed back to the power source through power electronics, or dissipated in a resistor.

Fig.10 shows the simulation results of phase current, rotor speed, flux-linkage and torque under different operating conditions: start-up, sudden change of load and braking. The simulation model shown in Fig.9 is capable of simulating all of these operations.

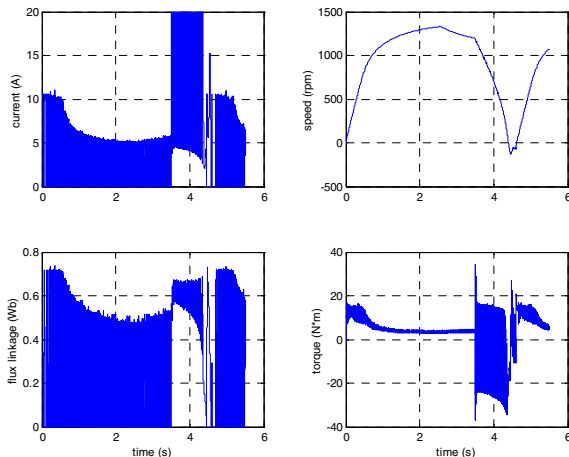

Fig.10 Simulation Results of Phase Current, Rotor Speed, Flux-linkage and Torque under Different Operating Conditions: Accelerating, Sudden Change of Load and Braking

The simulation consists of the motor starting up from 0 to 2.57 seconds, then an additional 3 Nm torque is added (the

turn-on and turn-off angles are kept the same) from 2.57 to 3.5 seconds. At 3.5 seconds the turn-on and turn-off angles are shifted by 30° so that the motor is operating in the braking condition, until the speed reduces to be 0 rpm. Finally at 4.60 seconds the SRM is returned to motoring operation and back to start up.

IV. RADIAL FORCES DURING TRANSIENT OPERATION

As long as the current waveform is known, the transient force can be calculated from the look-up table. Fig.11 shows the simulated phase current and rotor position. Notice that the rotor position is limited to be from 0 to 60° , which is required for the radial force calculations.

Fig.12 shows the calculated radial force (normal force) from look-up table technique, and its FFT. This radial force will be used later in the simulation model to predict the transient stator acceleration.

Fig.13 shows the radial force and its FFT, using the same technique as described above. Compared with Fig.12, which shows the radial force and its FFT during motor acceleration, the radial force shown in Fig.13 is much more complicated, due to the change in different operating conditions. The FFT results show that there are higher levels of harmonics in the radial force in addition to new force harmonics when the operating conditions are changing, which means there are more opportunities to excite the resonant frequency of the motor stator.

The current waveform can also be obtained from experiments. Fig.14 shows the recorded phase current waveform of the SRM at 1450RPM (no-load). With the known turn-on and turn-off angles, this current waveform is then used in the previous lookup table to calculate the normal force acting on the stator poles, as shown in Fig.15.

An FFT operation is carried out for the above normal force as shown in Fig.16. It has a DC component, fundamental and harmonics. The normal force magnitudes of all the harmonics are shown in this figure together with the frequencies. This result can be then used as input in the simulation model described in the next section; thus the output will be the simulated acceleration response.

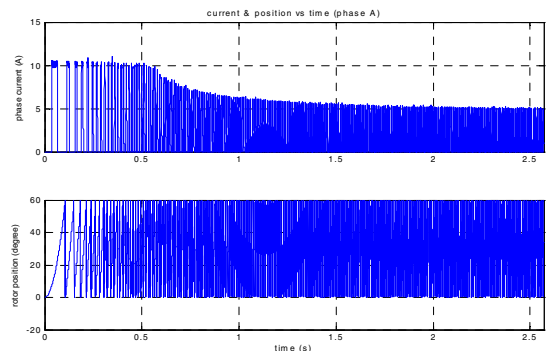

Fig.11 Simulated Phase Current and Rotor Position (start-up)

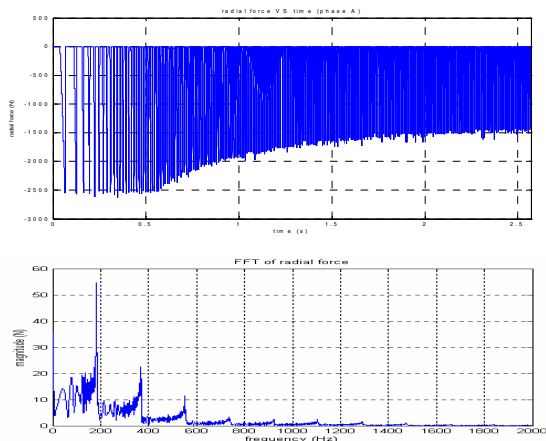

Fig.12 Simulated Normal Force and its FFT (start-up)

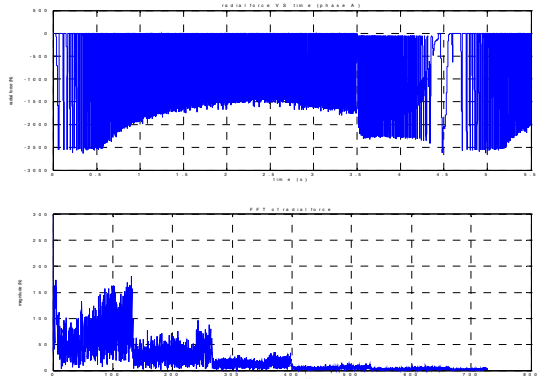

Fig.13 Simulated Radial Force and its FFT (start-up, sudden change of load and braking)

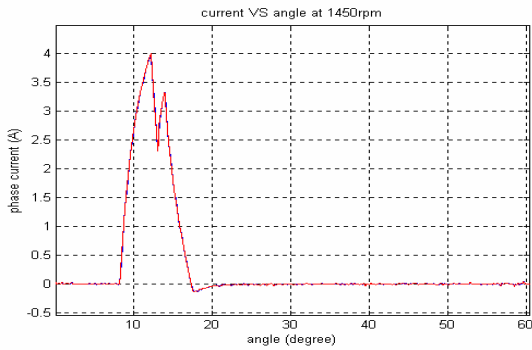

Fig.14 Measured SRM Phase Current at 1450RPM

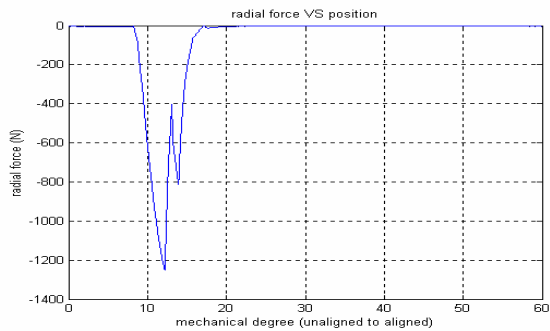

Fig.15 Normal Force Calculated from Look-up Table

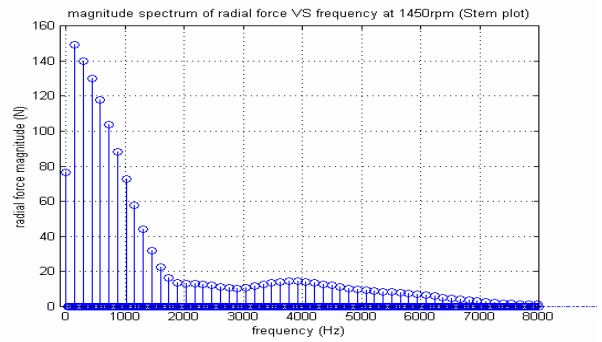

Fig.16 FFT Analysis Results of Normal Force

V. VIBRATION PREDICTION

From a vibration point of view, the SRM is a complicated Multi-Degree of Freedom (MDOF) system. However it can be represented as the linear superposition of a finite number of Single-Degree of Freedom (SDOF) systems, which can be modeled as a viscously damped spring-mass system. The transient equation of motion can be obtained using Newton's law:

$$m\ddot{x} + c\dot{x} + kx = F(t) \quad (4)$$

where the parameters can be obtained by transfer function identification with a series of experiments [8]. The solution of (4) is the transient vibration, including displacement response, velocity response and acceleration response.

Fig.17 shows the simulation block of the transient vibration in the SRM. The normal force is calculated from the look-up table, using phase current results from the simulation described in the previous section. Fig. 18 shows the acceleration response under constant speed. Fig.19 shows the simulated stator vibration and speed change during transient operation. Fig. 20 is the FFT analysis. Fig. 21 shows the 3-D view of acceleration spectra during different operation under different speeds.

It is very clear that there are abundant harmonics of frequency during transients, which means it is easier to excite resonances.

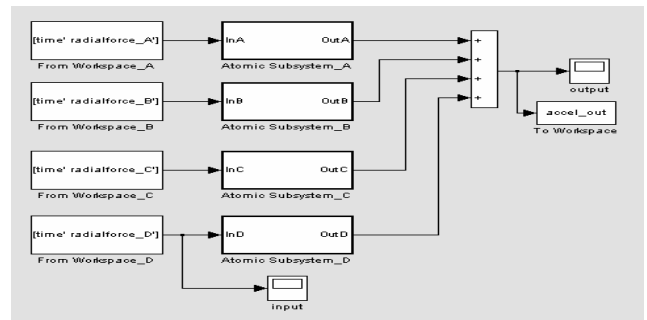

Fig.17 Transient Vibration Simulation from Normal Force to Stator Acceleration

VI. EXPERIMENT VALIDATION

An 8/6 4kW SRM is driven by the classical converter for the experiment. A resistor is connected to the converter in parallel to provide energy dissipation during generating/braking operation. A DC generator with resistance load is connected with the tested SRM as the load. dSPACE is used as the controller of the converter, which has the functions of DSP and AD/DA, and can be run under the environment of Matlab/Simulink.

The transient stator vibrations and phase currents are measured, as shown in Fig.22. Fig.22(a) shows the measured transient stator acceleration during start-up, (b) is the FFT of the vibration, (c) is the phase current. The measured acceleration and phase current are close enough to the simulated results, especially when the SRM reaches steady state.

Fig. 23 shows transient stator vibrations and its FFT during load change. It can be seen that as load increases, the vibration decreases. This is because the motor speed decreases with increase in load when turn-on and turn-off angles are keep unchangeable.

Fig.24 shows the transient stator vibration and its FFT during braking operation. At this operating status, the stored kinetic energy is converted into electric energy and dissipated in the resistor, and the electromagnetic torque is negative. Thus, the vibration decreases with an increase in speed. When speed falls to zero, the motor will restarted in the opposite direction.

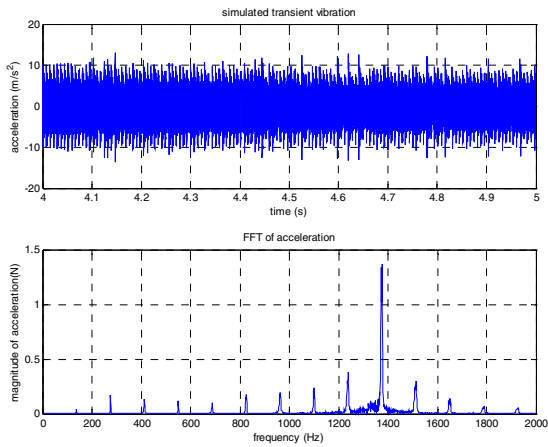

Fig.18 Acceleration Response in Time & Frequency Domain under 1320RPM

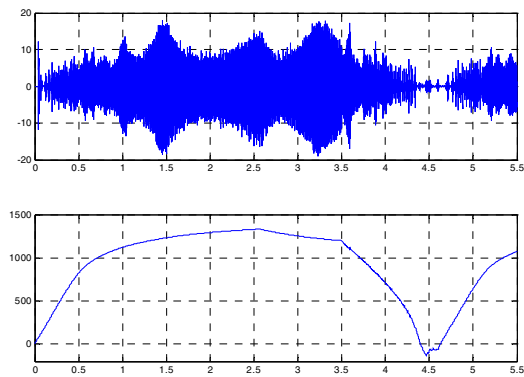

Fig.19 Simulated Vibration and Speed Change

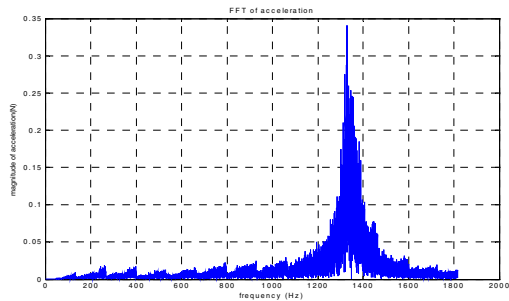

Fig.20 FFT Analysis of Transient Operation

magnitude spectrum of acceleration response under different speed (location #4)

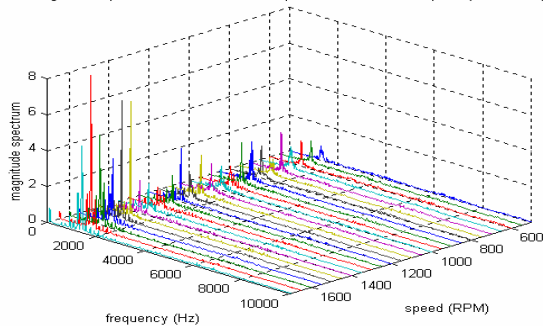

Fig.21 3-D View of Acceleration Spectra under Different Speeds

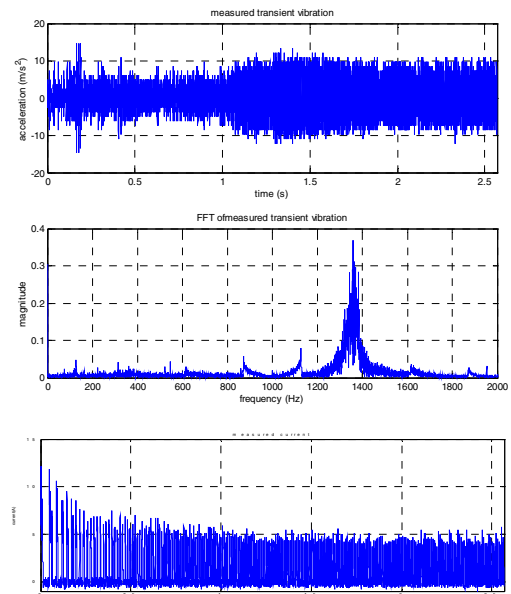

Fig.22 (a, b, c) Measured Transient Stator Vibration and Phase Current

VIII. ACKNOWLEDGEMENT

The authors acknowledge the support of Delphi Research Labs, Shelby Township, Michigan.

IV. REFERENCES

[1] D.E. Cameron, J.H. Lang, S.D. Umans, "The origin and reduction of acoustic noise in doubly salient variable-reluctance motors", *IEEE Trans. on Industry Applications*, Vol.28, No.6, November/December, 1992, pp.1250-1255.

[2] W.Cai, P.Pillay, Z.Tang, A.Omekanda, "Vibration Measurements in the Switched Reluctance Motor", 2001 Industry Application Society Annual Meeting, Sept.30~Oct.4, 2001, Chicago, Illinois, USA.

[3] P.Pillay, W. Cai, "Investigation into vibration in switched reluctance motor", *IEEE Transactions on Industry Applications*, v 35, n 3, 1999, p 589-596.

[4] W.Cai, P.Pillay and A.Omekanda, "An analytical model to predict the modal frequencies of switched reluctance motors", *IEEE IEMDC*, Boston, MA, June 2001, pp. 203-207.

[5] P.J. Lawrenson, J.M. Stephenson, P.T. Blenkinson, J. Corda and N.N. Fulton, "Variable-speed switched reluctance motors", *IEE Proc.*, vol. 127, pt. B, no. 4, pp. 253-265, July 1980.

[6] Giovanni Franceschini, Stefano Pirani, Mario Rinaldi, Carla Tassoni, "Spice-Assisted Simulation of Controlled Electric Drives: An Application to Switched Reluctance Drives", *IEEE Trans. on Industry Applications*, Vol.27, No.6, Nov./Dec. 1991, pp.1103~1110.

[7] F.Souares, P.J.Costa Branco, "Simulation of a 6/4 Switched Reluctance Motor Based on Matlab/Simulink Environment", *IEEE Trans. on Aerospace and Electronic Systems*, Vol.37, No.3, July 2001, pp.989~1009.

[8] Z.Tang, P.Pillay, "Vibration Prediction in Switched Reluctance Motors with Transfer Function Identification from Shaker and Force Hammer Tests", *IAS'2002 Annual Meeting*, October 13th~17th, Pittsburgh, PA.

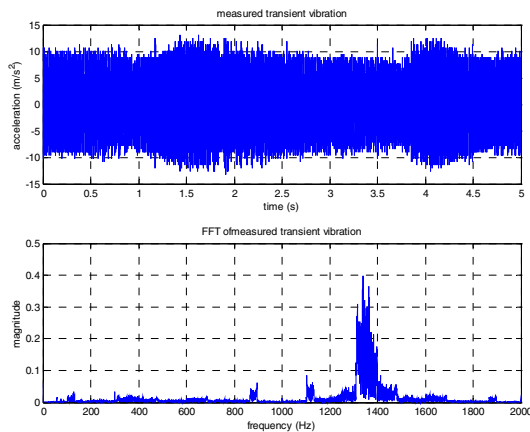

Fig.23 Measured transient stator vibration and FFT during load change

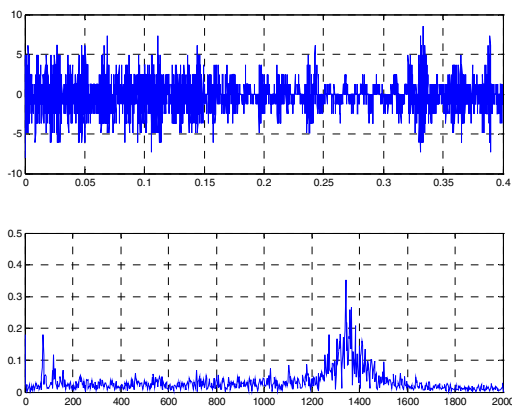

Fig.24 Measured transient stator vibration and FFT during braking

It should be emphasized that although the vibrations during startup and braking do not significantly change compared with constant operation in this experiment, there exist more cases to excite resonance during these operations since there are more harmonics of the exciting force. The FFT analysis in Fig. 23 shows that the maximum acceleration response is around 1380 Hz, which is the natural resonant frequency of this motor.

VII. CONCLUSIONS

The vibration prediction model developed in this paper is built based on the detailed normal force vs. phase current and rotor position lookup table using finite element calculations. It is useful and practical, and is verified by the running motor test, which shows acceptable accuracy. The results reveal that there are abundant harmonics of transient force during operation change, and that the resonant vibration can be excited. This program now allows the possibility of using the simulation model to improve design of SRMs from a vibration and acoustic noise point of view.