

Problem 1

Suppose $v_s = 18 \text{ V}$. Determine the value of the current measured by the ammeter in this circuit:

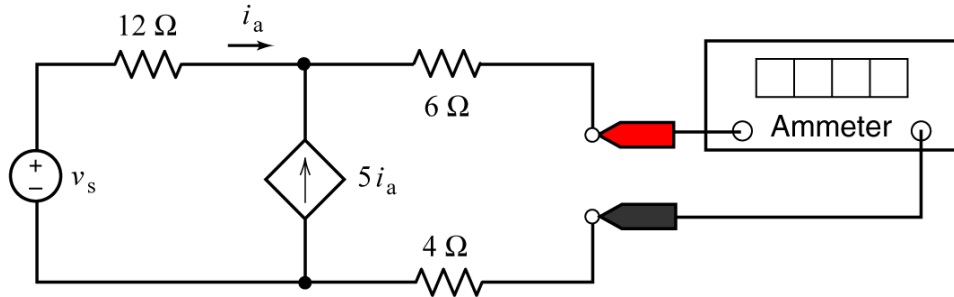

Solution 1

First, replace the (ideal) ammeter by a short circuit and label the current measured by the ammeter. Also, we will add the name of the dependent source current to its label.

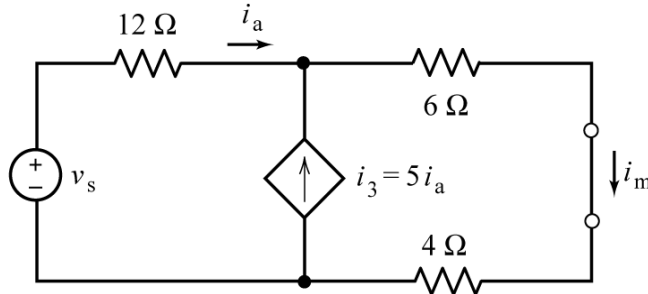

Next, label the currents in the series elements.

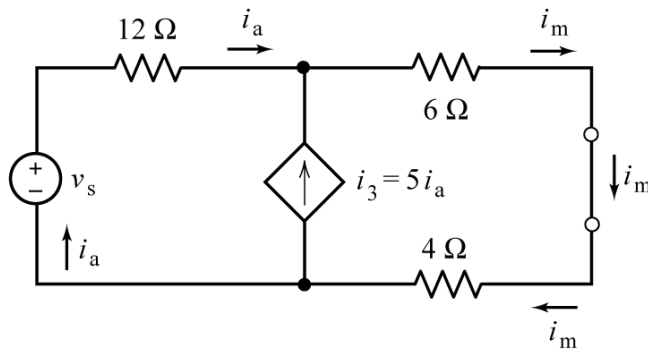

Label the resistor voltages using Ohm's law.

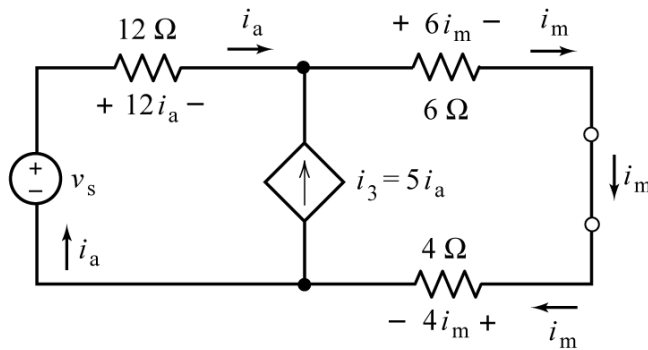

All that remains is to label the voltage across the dependent source.

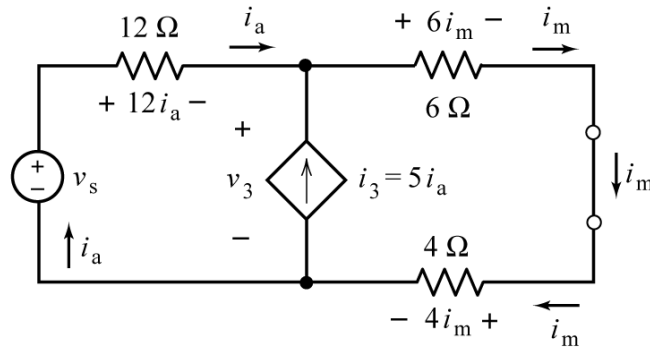

Apply KCL at the top node of the dependent source to write

$$i_a + 5i_a = i_m \Rightarrow i_a = \frac{i_m}{6}$$

Apply KVL to the outside loop to write

$$12i_a + 6i_m + 4i_m - v_s = 0 \Rightarrow 12\left(\frac{i_m}{6}\right) + 6i_m + 4i_m = v_s \Rightarrow i_m = \frac{v_s}{12}$$

When $v_s = 18 \text{ V}$ the current measured by the ammeter is $i_m = 1.5 \text{ A}$.

Problem 2

Suppose $v_s = 15 \text{ V}$. Determine the value of the voltage measured by the voltmeter in this circuit:

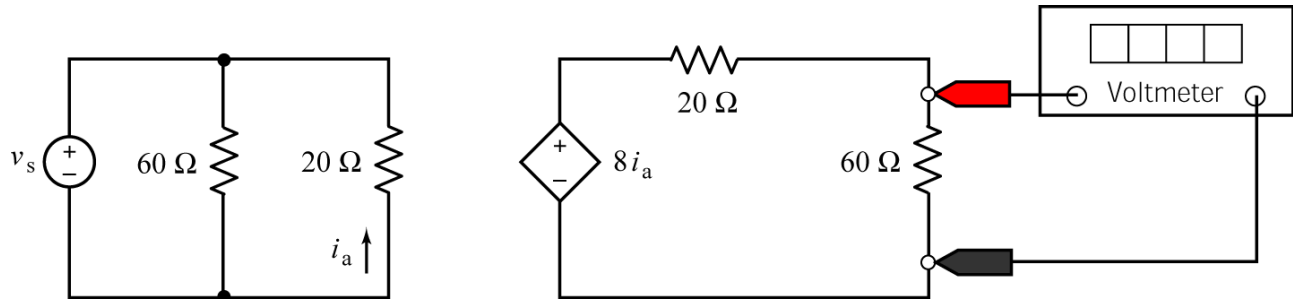

Solution 2

First, replace the (ideal) voltmeter by an open circuit and label the voltage measured by the voltmeter. Also, we will add the name of the dependent source voltage to its label.

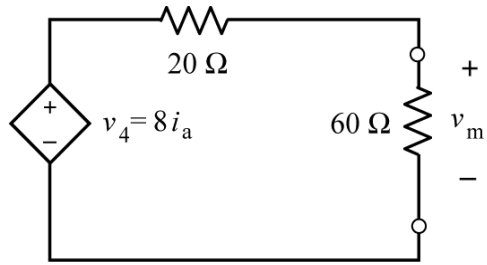
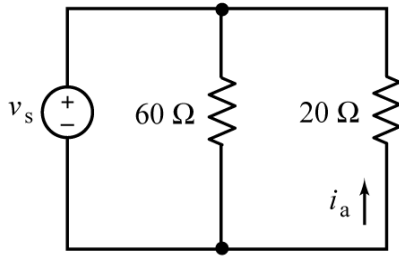

Use Ohm's law to label the current in the 60Ω resistor on the right side of the circuit.

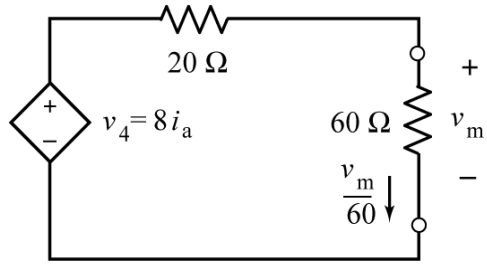
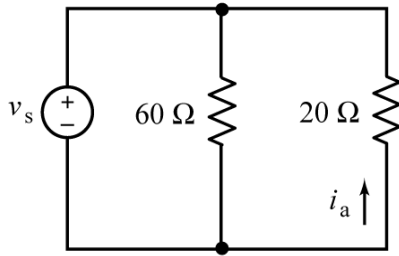

Label the voltages across parallel elements and the currents in series elements.

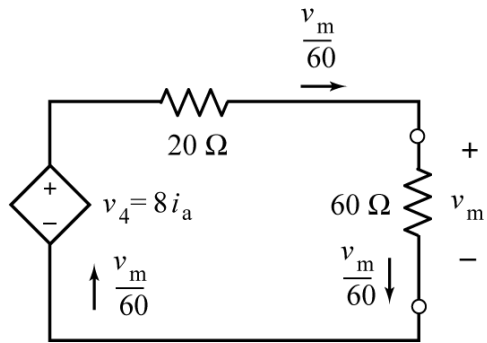
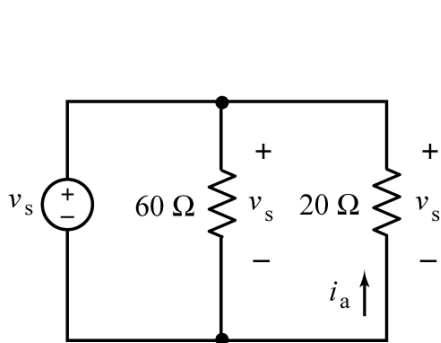

Use Ohm's law to label remaining resistor currents and voltages.

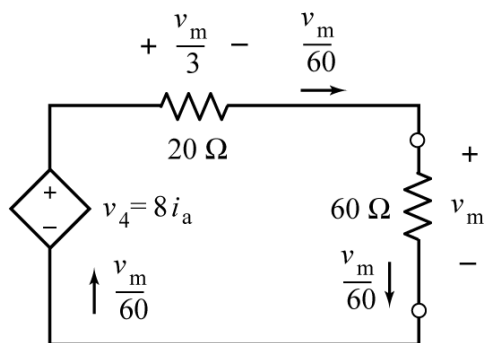
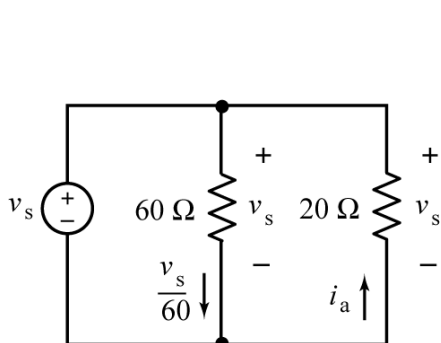

It remains only to label the current in the independent voltage source.

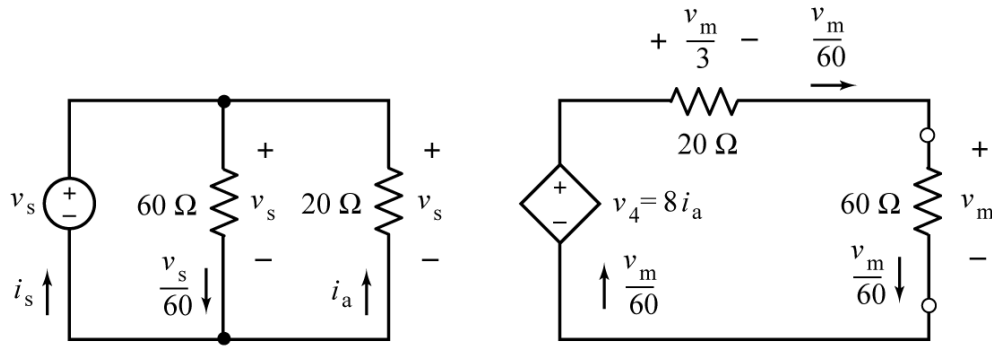

Notice that i_a and v_s , the current and voltage of the vertical $20\ \Omega$ resistor, do not adhere to the passive convention. Consequently, Ohm's law gives

$$i_a = -\frac{v_s}{20}$$

Apply KVL at the right side of the circuit to get

$$\begin{aligned} \frac{v_m}{3} + v_m - v_4 &= 0 \Rightarrow \frac{v_m}{3} + v_m - 8i_a = 0 \\ &\Rightarrow \frac{v_m}{3} + v_m - 8\left(-\frac{v_s}{20}\right) = 0 \\ &\Rightarrow \frac{4}{3}v_m = -8\left(\frac{v_s}{20}\right) \Rightarrow v_m = -\frac{3}{10}v_s \end{aligned}$$

When $v_s = 15\ \text{V}$ the voltage measured by the voltmeter is $v_m = -4.5\ \text{V}$.