

Superposition

The response of a linear circuit to several inputs working together is equal to the sum of the responses to each input working separately.

Circuit Inputs and Outputs

- Inputs are usually the voltages of *independent* voltage sources and the currents of *independent* current sources.
- Outputs can be any current or voltage.
- The circuit designer designates the input and output of the circuit.
- A circuit can have more than one input and/or output.

Linearity

A linear circuit, without capacitors or inductors, is represented by an algebraic equation of the form:

$$v_o = a_1 v_1 + a_2 v_2 + \dots + a_n v_n$$

where

- v_o is the output of the circuit (it could be a current instead of a voltage).
- v_1, v_2, \dots, v_n are the inputs to the circuit (any or all of the inputs could be currents instead of voltages).
- The coefficients a_1, a_2, \dots, a_n are real constants, called gains.

We say that the output of the circuit is a linear combination of the inputs to the circuit. To determine a_1 , set v_2, v_3, \dots, v_n to zero. Then

$$a_1 = \frac{v_o}{v_1} \Bigg|_{v_2, v_3, \dots, v_n = 0}$$

The other gains are determined similarly.

Example

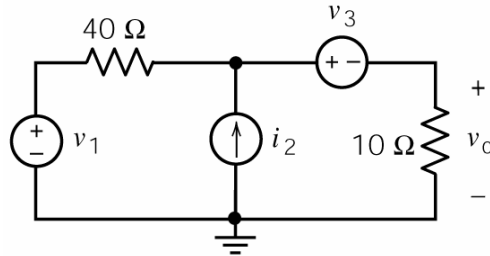

This circuit has one output, v_o , and three inputs, v_1 , i_2 and v_3 . (As expected, the inputs are voltages of independent voltage sources and the currents of independent current sources.) Express the output as a linear combination of the inputs.

Solution

Let's analyze the circuit using node equations. Label the node voltage at the top node of the current source and identify the supernode corresponding to the horizontal voltage source.

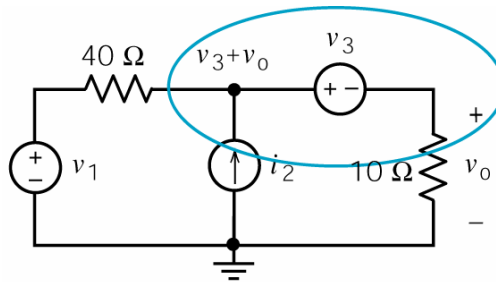

Apply KCL to the supernode to get

$$\frac{v_1 - (v_3 + v_o)}{40} + i_2 = \frac{v_o}{10}$$

Multiply both sides of this equation by 40 to eliminate the fractions

$$v_1 - (v_3 + v_o) + 40i_2 = 4v_o \Rightarrow v_1 + 40i_2 - v_3 = 5v_o$$

Dividing both sides by 5, expresses the output as a linear combination of the inputs:

$$v_o = \frac{v_1}{5} + 8i_2 - \frac{v_3}{5}$$

Also

$$a_1 = \left. \frac{v_o}{v_1} \right|_{i_2, v_3 = 0} = \frac{1}{5} \text{ V/V}, a_2 = \left. \frac{v_o}{i_2} \right|_{v_1, v_3 = 0} = 8 \text{ V/A} \text{ and } a_3 = \left. \frac{v_o}{v_3} \right|_{v_1, i_2 = 0} = -\frac{1}{5} \text{ V/V}$$

Alternate Solution

Consider the circuit itself when $i_2, v_3 = 0$. (A zero current source is equivalent to an open circuit and a zero voltage source is equivalent to a short circuit.)

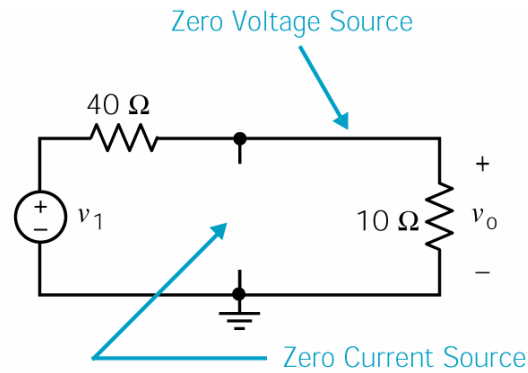

Using voltage division

$$v_o = \frac{10}{40+10} v_1 = \frac{1}{5} v_1$$

In other words

$$a_1 = \left. \frac{v_o}{v_1} \right|_{i_2, v_3 = 0} = \frac{1}{5} \text{ V/V}$$

Next, consider the circuit itself when $v_1, v_3 = 0$.

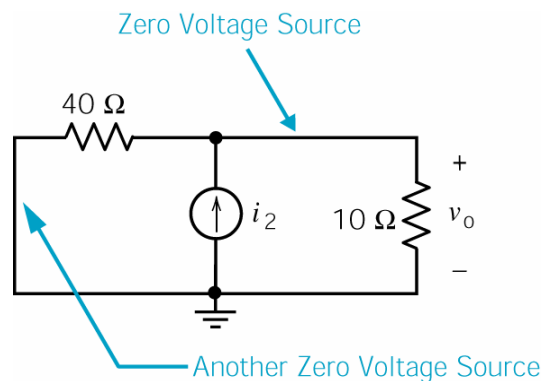

The resistors are connected in parallel. Applying Ohm's law to the equivalent resistance gives

$$v_o = \frac{40 \times 10}{40 + 10} i_2 = 8 i_2$$

In other words

$$a_2 = \frac{v_o}{i_2} \Big|_{v_1, v_3 = 0} = 8 \text{ V/A}$$

Finally, consider the circuit itself when $i_2, v_3 = 0$.

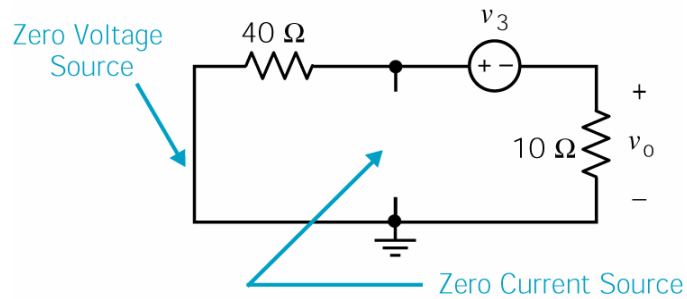

Using voltage division

$$v_o = \frac{10}{40+10} (-v_3) = -\frac{1}{5} v_3$$

In other words

$$a_3 = \frac{v_o}{v_3} \Big|_{v_1, i_2 = 0} = -\frac{1}{5} \text{ V/V}$$

Now the output can be expressed as a linear combination of the inputs

$$v_o = a_1 v_1 + a_2 i_2 + a_3 v_3 = \frac{1}{5} v_1 + 8 i_2 + \left(-\frac{1}{5}\right) v_3$$

as before.

Summary

When the voltages of all independent voltage sources and the currents of all independent current sources are inputs to a linear circuit, then

The response of the linear circuit to several inputs working together is equal to the sum of the responses to each input working separately.

To calculate the response to one input working separately, set all other inputs to zero. (A zero current source is equivalent to an open circuit and a zero voltage source is equivalent to a short circuit.)

Example

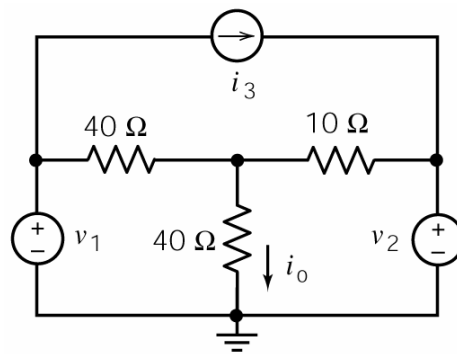

This circuit has one output, i_o , and three inputs, v_1 , i_2 and v_3 . Express the output as a linear combination of the inputs.

Solution

When $v_2, i_3 = 0$:

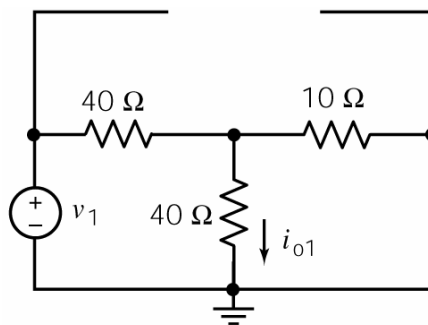

Writing a node equation:

$$\frac{v_1 - 40i_{o1}}{40} = \frac{40i_{o1}}{40} + \frac{40i_{o1}}{10} = 5i_{o1} \Rightarrow v_1 - 40i_{o1} = 200i_{o1} \Rightarrow i_{o1} = \frac{v_1}{240}$$

When $v_1, i_3 = 0$:

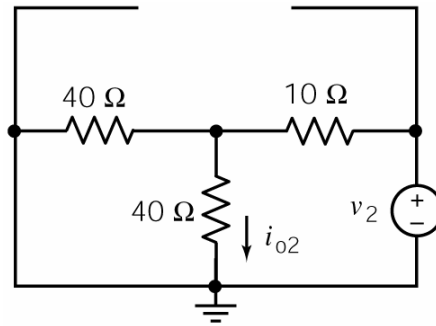

Writing a node equation:

$$\frac{v_2 - 40i_{o2}}{10} = \frac{40i_{o2}}{40} + \frac{40i_{o2}}{40} = 2i_{o2} \Rightarrow v_2 - 40i_{o2} = 20i_{o2} \Rightarrow i_{o2} = \frac{v_2}{60}$$

When $v_1, v_2 = 0$:

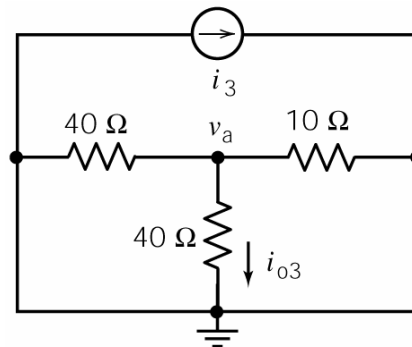

Writing a node equation:

$$\frac{v_a}{40} + \frac{v_a}{40} + \frac{v_a}{10} = 0 \Rightarrow v_a = 0 \Rightarrow i_{o3} = \frac{v_a}{40} = 0$$

The response of the linear circuit to several inputs working together is equal to the sum of the responses to each input working separately. Consequently

$$i_o = i_{o1} + i_{o2} = i_{o3} = \frac{v_1}{240} + \frac{v_2}{60} + 0$$

Alternate Solution:

Let's analyze the circuit using node equations. Label the node voltage at the top node of the vertical resistor:

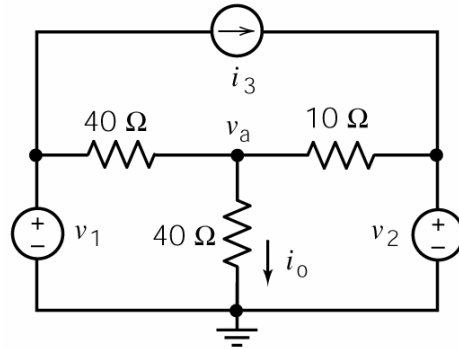

The node equation is

$$\frac{v_a - v_1}{40} + \frac{v_a}{40} + \frac{v_a - v_2}{10} = 0 \Rightarrow 6v_a = v_1 + 4v_2 \Rightarrow v_a = \frac{v_1}{6} + \frac{2}{3}v_2$$

Using Ohm's law, we get

$$i_o = \frac{v_a}{40} = \frac{v_1}{240} + \frac{v_2}{60}$$

as before.

It's easier to solve this particular problem without using superposition. That's not always the case.