

EE221 - Practice for the 1st Midterm Exam

1. Consider this circuit and corresponding plot of the inductor current:

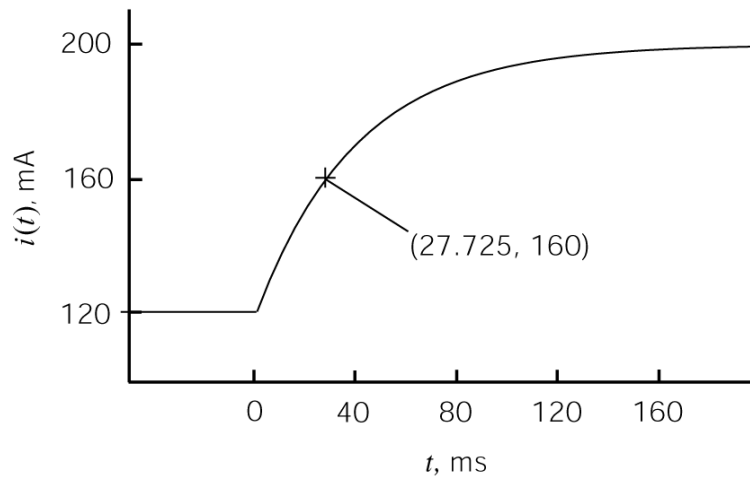
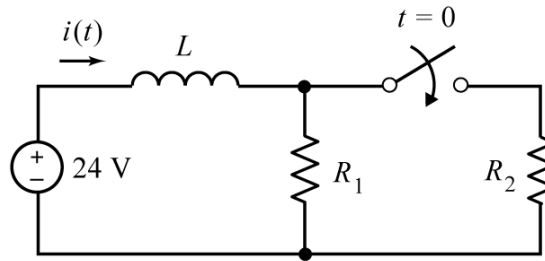

Determine the values of L , R_1 and R_2 : $L = \underline{4.8}$ H, $R_1 = \underline{200}$ Ω and $R_2 = \underline{300}$ Ω .

Hint: Use the plot to determine values of D , E , F and a such that the inductor current can be represented as

$$i(t) = \begin{cases} D & \text{for } t \leq 0 \\ E + F e^{-at} & \text{for } t \geq 0 \end{cases}$$

2.

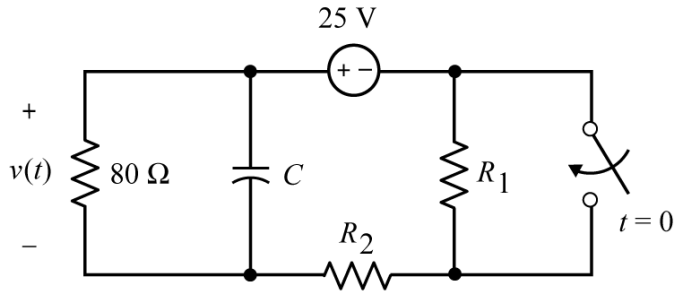

(a)

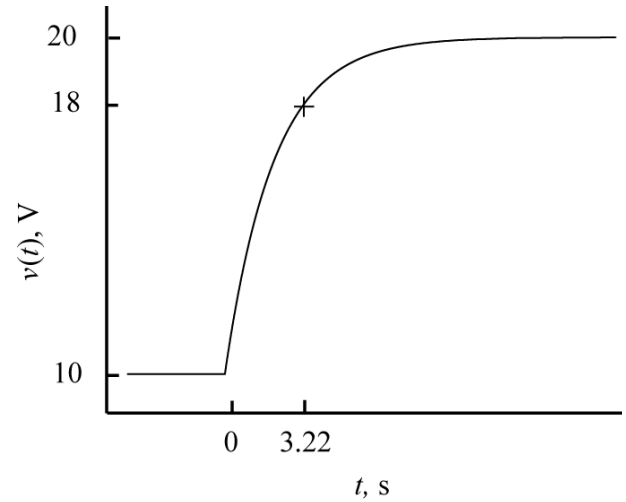

(b)

Design the circuit in (a) to have the response in (b) by specifying the values of C , R_1 and R_2 .

$C = \underline{0.125} \text{ F}$, $R_1 = \underline{100} \text{ } \Omega$ and $R_2 = \underline{20} \text{ } \Omega$.

3. Given that

$$v_i(t) = 24 \cos(3t + 75^\circ) \text{ V}$$

answer the following questions:

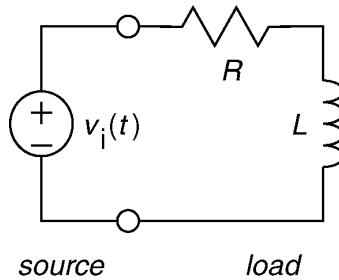

a) Suppose $R = 9 \text{ } \Omega$ and $L = 5 \text{ H}$. What are the average, complex and reactive powers delivered by the source to the load?

$P = \underline{8.47} \text{ W}$, $\mathbf{S} = \underline{8.47 + j14.1} \text{ VA}$ and $Q = \underline{14.1} \text{ VAR}$

b) Suppose the source delivers $8.47 + j 14.12 \text{ VA}$ to the load. What are the values of the resistance, R , and the inductance, L ?

$R = \underline{9} \text{ } \Omega$ and $L = \underline{5} \text{ H}$

c) Suppose the source delivers 14.12 W to the load at a power factor of 0.857 lagging. What are the values of the resistance, R , and the inductance, L ?

$R = \underline{15} \text{ } \Omega$ and $L = \underline{3} \text{ H}$

4. Given that

$$v_i(t) = 24 \cos(3t + 75^\circ) \text{ V}$$

Determine the impedance of the load and the complex power delivered by the source to the load under each of the following conditions:

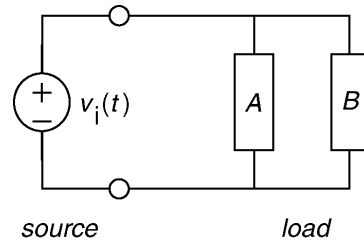

a) The source delivers $14.12 + j 8.47$ VA to load A and $8.47 + j 14.12$ VA to load B.

$$\mathbf{Z} = \underline{\quad 9.016 \angle 45^\circ \quad} \Omega, \mathbf{S} = \underline{\quad 22.59 + j22.59 \quad} \text{VA}$$

b) The source delivers $8.47 + j 14.12$ VA to load A and the impedance of load B is $15 + j9 \Omega$.

$$\mathbf{Z} = \underline{\quad 9.016 \angle 45^\circ \quad} \Omega, \mathbf{S} = \underline{\quad 22.59 + j22.59 \quad} \text{VA}$$

c) The source delivers 14.12 W to load A at a power factor of 0.857 lagging and the impedance of load B is $9 + j15 \Omega$.

$$\mathbf{Z} = \underline{\quad 9.016 \angle 45^\circ \quad} \Omega, \mathbf{S} = \underline{\quad 22.59 + j22.59 \quad} \text{VA}$$

d) The impedance of load A is $15 + j9 \Omega$ and the impedance of load B is $9 + j15 \Omega$.

$$\mathbf{Z} = \underline{\quad 9.016 \angle 45^\circ \quad} \Omega, \mathbf{S} = \underline{\quad 22.59 + j22.59 \quad} \text{VA}$$

5. In this circuit an ac source is connected to a load by the line. The load voltage is $\mathbf{V}_L = 120 \angle 0^\circ$ Vrms and the load receives 50 W at a power factor of 0.8 lagging. The line current is

$$\mathbf{I} = 0.5208 \angle -36.87^\circ \text{ Arms}$$

Determine the RMS value of required source voltage, $v_s(t)$, and the average power supplied by the source, P_s .

$$|\mathbf{V}_s| = \underline{\quad 124.2 \quad} \text{Vrms and } P_s = \underline{\quad 52.71 \quad} \text{W}$$

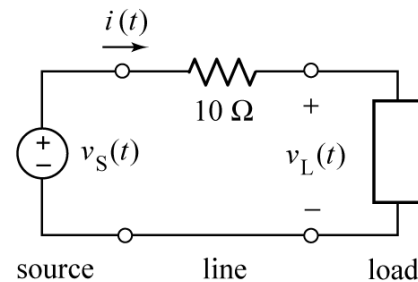

6. In this circuit an ac source is connected to a load by the line. The load voltage is $\mathbf{V}_L = 120 \angle 0^\circ$ Vrms and the load receives 50 W at a power factor of 0.8 lagging. The line current is

$$\mathbf{I} = B \angle \phi \text{ Arms}$$

Determine the values of B and ϕ .

$$B = \underline{\quad 0.5208 \quad} \text{Arms and } \phi = \underline{\quad -36.87 \quad}^\circ$$

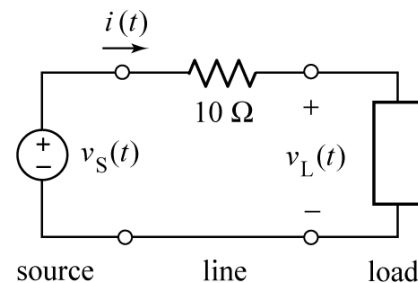

7. The input to this circuit shown is

$$v_s(t) = 12 \cos(5t) \text{ V}$$

The impedance of the load is $20 + j15 \Omega$.

Noticing that $i_1(t)$ and $i_2(t)$ are mesh currents, we can represent this circuit by the mesh equations

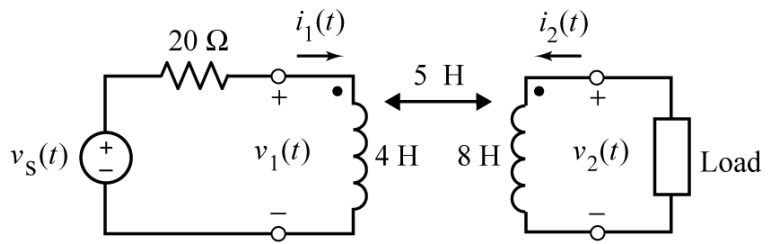

$$\begin{bmatrix} 20 + ja & jb \\ jc & 20 + jd \end{bmatrix} \begin{bmatrix} \mathbf{I}_1 \\ \mathbf{I}_2 \end{bmatrix} = \begin{bmatrix} 12 \angle 0^\circ \\ 0 \end{bmatrix}$$

where $a, b, c,$ and d are real constants. Determine the values of $a, b, c,$ and d .

$$a = \underline{20} \Omega, \quad b = \underline{25} \Omega, \quad c = \underline{25} \Omega, \quad \text{and} \quad d = \underline{55} \Omega$$

8. This circuit consists of a source connected to a load by coupled coils. The input is

$$v_s(t) = 12 \cos(5t) \text{ V}$$

The impedance of the load is $20 + j15 \Omega$.

The mesh currents $i_1(t)$ and $i_2(t)$ are

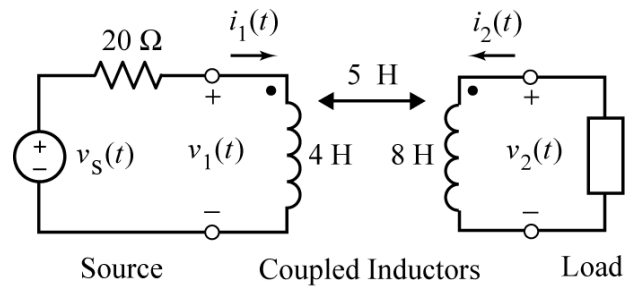

$$i_1(t) = 0.4676 \cos(5t - 22.8^\circ) \text{ A} \quad \text{and} \quad i_2(t) = 0.1998 \cos(5t - 2.86^\circ) \text{ A}$$

Determine the values of \mathbf{S} , the complex power supplied by the source, \mathbf{S}_c , the complex power received by the coupled inductors and \mathbf{S}_L , the complex power received by the load.

$$\mathbf{S} = \underline{2.5855} + j \underline{1.0893} \text{ VA}, \quad \mathbf{S}_c = \underline{0} + j \underline{0.79} \text{ VA} \quad \text{and} \quad \mathbf{S}_L = \underline{0.399} + j \underline{0.299} \text{ VA}$$

9. Here is a circuit containing coupled coils, represented in the frequency domain. The currents \mathbf{I}_1 and \mathbf{I}_2 are mesh currents. The mesh equations representing this circuit can be expressed as

$$(a + jb)\mathbf{I}_1 + (c + jd)\mathbf{I}_2 = 15 \angle 30^\circ$$

$$(c + jd)\mathbf{I}_1 + (80 + jf)\mathbf{I}_2 = 0$$

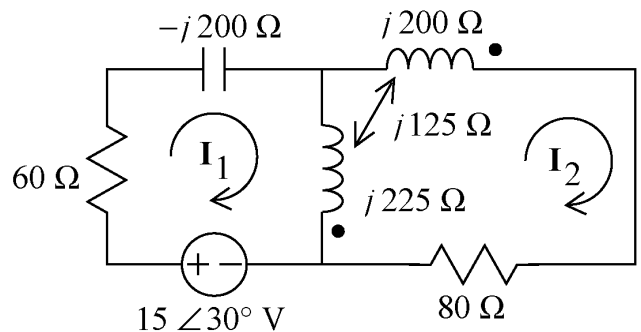

where $a + jb, c + jd,$ and $40 + jf$ represent complex numbers in rectangular form. Determine the following:

$$a = \underline{60}, \quad b = \underline{25}, \quad c = \underline{0}, \quad d = \underline{-100}, \quad f = \underline{175}$$

10. The current $i(t)$ and voltage $v(t)$ labeled on the circuit drawing are

$$i(t) = \underline{0.316} \cos(3t - 31.6^\circ) \text{ A}$$

and

$$v(t) = \underline{2.85} \cos(3t + \underline{58.4}^\circ) \text{ V}$$

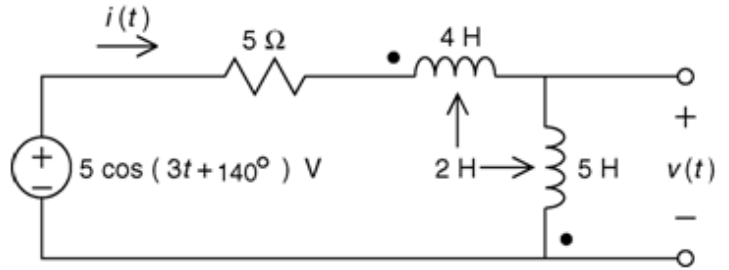

11. The current $i(t)$ and voltage $v(t)$ labeled on the circuit drawing are

$$i(t) = \underline{1.87} \cos(4t - 51.3^\circ) \text{ A}$$

and

$$v(t) = \underline{45} \cos(4t - \underline{51.3}^\circ) \text{ V}$$

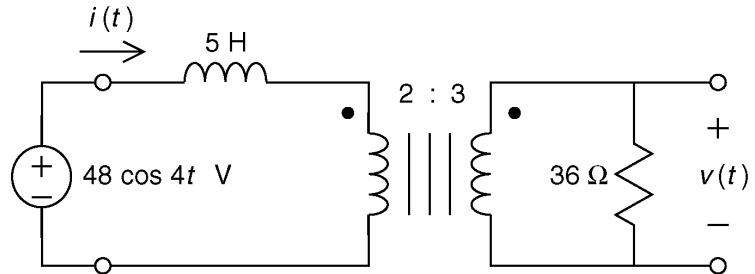

12.

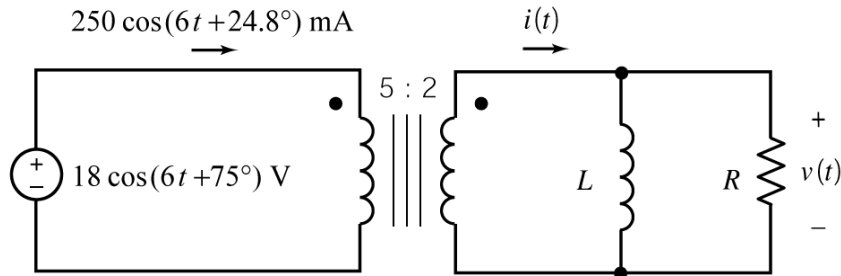

Determine the values of R and L : $R = \underline{18} \Omega$ and $L = \underline{2.5} \text{ H}$

13. This circuit consists of a load connected to a source through an ideal transformer. The input to the circuit is

$$v_s(t) = 12 \cos(20t) \text{ V}$$

Determine the values of the turns ratio, n , and load inductance, L , required for maximum power transfer to the load.

$$n = \underline{4} \text{ and } L = \underline{4} \text{ H}$$

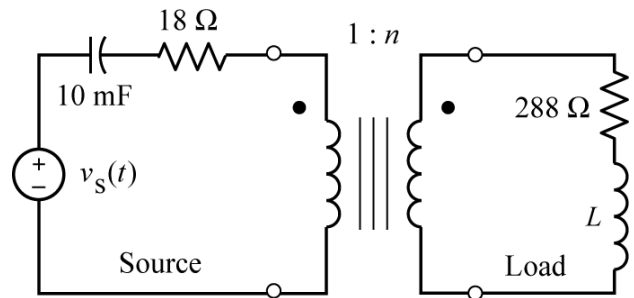

14. This circuit consists of a load connected to a source through an ideal transformer. The input to the circuit is

$$v_s(t) = 12 \cos(20t) \text{ V}$$

The coil voltages and currents are

$$v_1(t) = A \cos(20t + 15.5^\circ) \text{ V},$$

$$v_2(t) = B \cos(20t + 15.5^\circ) \text{ V}$$

$$i_1(t) = C \cos(20t) \text{ A} \text{ and } i_2(t) = D \cos(20t + 180) \text{ A}$$

Determine the values of A , B , C and D .

$$A = \underline{6.227} \text{ V}, \quad B = \underline{24.91} \text{ V}, \quad C = \underline{3.33} \text{ A} \text{ and } D = \underline{0.0833} \text{ A}$$

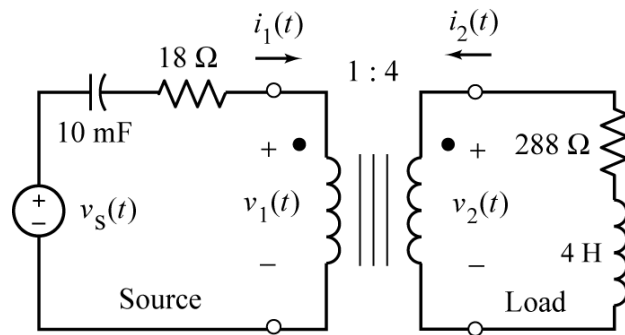

15. This circuit consists of a load connected to a source through an ideal transformer. The input to the circuit is

$$v_s(t) = 12 \cos(20t) \text{ V}$$

The coil voltages and currents are

$$v_1(t) = 6.227 \cos(20t + 15.5^\circ) \text{ V},$$

$$v_2(t) = 24.91 \cos(20t + 15.5^\circ) \text{ V}$$

$$i_1(t) = 0.333 \cos(20t) \text{ A} \text{ and } i_2(t) = 0.0833 \cos(20t + 180) \text{ A}$$

Determine the values of \mathbf{S}_p , the complex power received by the primary (left) coil of the transformer and \mathbf{S}_L , the complex power received by the load.

$$\mathbf{S}_p = \underline{1} + j \underline{0.277} \text{ VA} \text{ and } \mathbf{S}_L = \underline{1} + j \underline{0.277} \text{ VA}$$

